

Hoffman|Controls

Installation & Operating Instructions

759-ECM

Variable Speed Evaporator Fan Controller

Introduction



CAUTION

Failure to read and understand the accompanying instructions and diagrams prior to energizing the Controller may result in permanent damage to the Controller.

The 759-ECM Controller can be used with new or existing equipment, can be used with mechanical or electronic expansion valves, is not refrigerant specific and can be applied to a wide range of walk in and reach in Coolers and Freezers.

Installation is simple and does not require changes to the thermostat or compressor wiring. Simply attach four temperature sensors, connect power to the Controller, and install the variable speed ECM motor(s). The 759-ECM Controller requires no programming or set-up, will learn the vault conditions, and optimize the fan speed for maximum efficiency.

Pre-Installation Information/ Instruction

1. The 759-ECM Controller requires an external 24Vac (+20%/-10%), 4VA power source. The Controller 24Vac power source can be any 24Vac supply for Cooler/Medium Temperature applications that do not require defrost. For Freezer applications, the 24Vac power source must be derived from the evaporator fan motor(s) line voltage power source to ensure the Controller 24Vac power source and fan motor(s) are cutoff during the defrost cycle.
2. The Controller is condensation resistant and may be mounted inside or outside of the walk-in/reach-in Cooler or Freezer and is rated for -4°F to +125°F operation. An optional 759 Enclosure Kit p/n 520-0121-003 is available.
3. One Controller may control more than one ECM motor. The ECM motor must be capable of variable speed control via a PWM, 0-10Vdc or 10-0Vdc control signal. The maximum Controller motor drive load must not exceed 100ma. 100ma can typically drive 12 motors of either PWM, 0-10Vdc or 10-0Vdc type. You can also use a combination of PWM and 0-10Vdc type motors as long as the total load does not exceed 100ma. 10-0Vdc and PWM combinations can not be used. The Controller PWM output is 0% to 100% @ 80Hz with an amplitude of 17.5Vdc. See the ECM motor manufacturers input drive specifications for motor input control signal type and loading.
5. Sensor wires can be extended up to 25 feet. It is recommended that the wire be 22AWG, twisted pair wire.



WARNING

Disconnect power from the compressor and evaporator coil unit prior to installation.

Installation

1. Select an appropriate location to mount the 759-ECM Controller using the supplied Self Drilling #8X1 Screws. Mounting may be inside or outside of the Cooler or Freezer vault. The Controller is typically mounted on the Evaporator Fan Box in a visible position inside the vault.

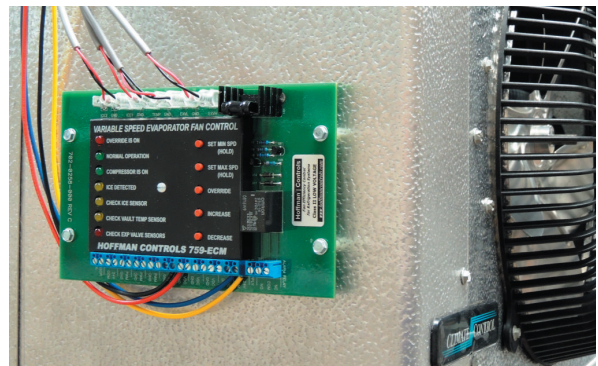

- 1a. An optional weatherproof Enclosure Kit p/n 520-0121-003 is available for inside/outside vault or outdoor installations.

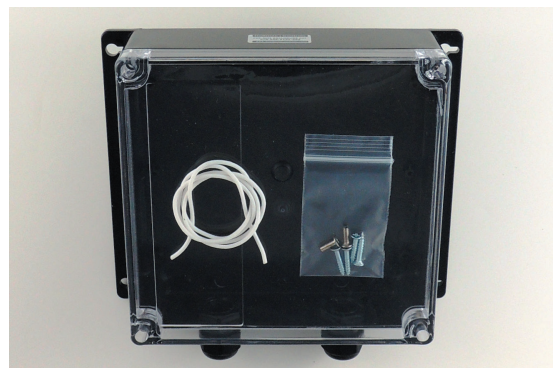

- 1b. The Controller must be mounted outside of the vault for Freezer applications that operate below -4°F.



Installation Con't

2. Once the Controller is mounted, begin sensor installation. There are four sensors to be installed. Vault Temperature Sensor, Expansion Valve Low Pressure Side Sensor, Expansion Valve High Pressure Side Sensor and Evaporator Coil Ice Sensor. The four sensors are supplied with the Controller and are identical. Each sensor has two leads. Either lead can be connected to the terminals labelled GND. An optional fifth sensor can be purchased, p/n 100-0016-001 and used as a second Evaporator Coil Ice Sensor should there be two evaporator coils in use.

2a. Use the supplied cable clamp and screw to mount the Cooler/Freezer Vault Temperature Sensor on the vault wall. It should be mounted directly behind the evaporator coil and centrally located on the vault wall to provide accurate vault temperature readings to the Controller. Connect the sensor leads to the terminals labeled TEMP & GND per the wiring diagram on Page 7.



2b. Mount two of the sensors on the Expansion Valve using the supplied insulating tape as shown below. Stretch the tape slightly as you wrap the sensor that is mounted on the Expansion Valve lines. Use all the tape, lapping the sensor. Additional tape such as electrical or duct tape can be used to ensure the sensors stay in place. Firm contact is required between the metal can of the sensor and the lines. Connect the Low Side Sensor to terminals EXVL & GND and the High Side Sensor to terminals EXVH & GND per the wiring diagram on Page 7.

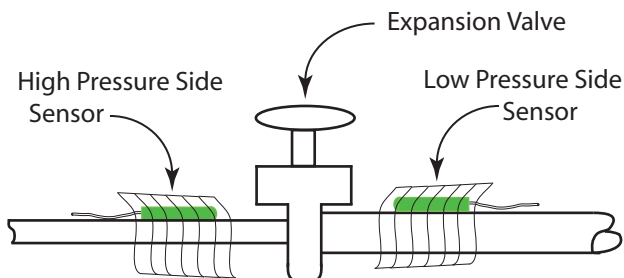

Installation Con't

2b (con't). Typical expansion valve sensor mounting is shown below. See installation step (7.) for optional direct line compressor "ON" detection using the thermostat signal or compressor contactor.

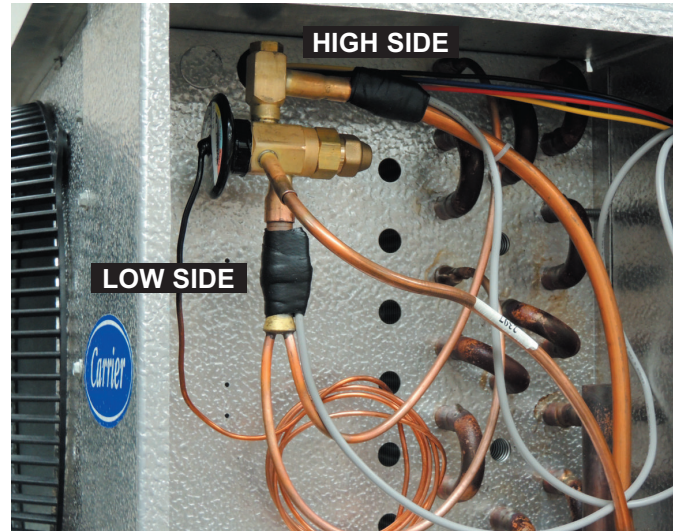

3. Mount the Evaporator Coil Ice Sensor below one of the motors about a quarter of the way up from the bottom of the coil. Typically this is between the second and third coil tube from the bottom. If it is a two fan evaporator, you can mount the sensor below either motor. If there are three or more motors, mount the sensor below one of the center motors. Once a location is determined, spread the coil fins slightly apart and insert the sensor metal can. Then use a pair of needle nose pliers to pinch the fins together above and below the sensor metal can to secure the sensor in place as shown below.

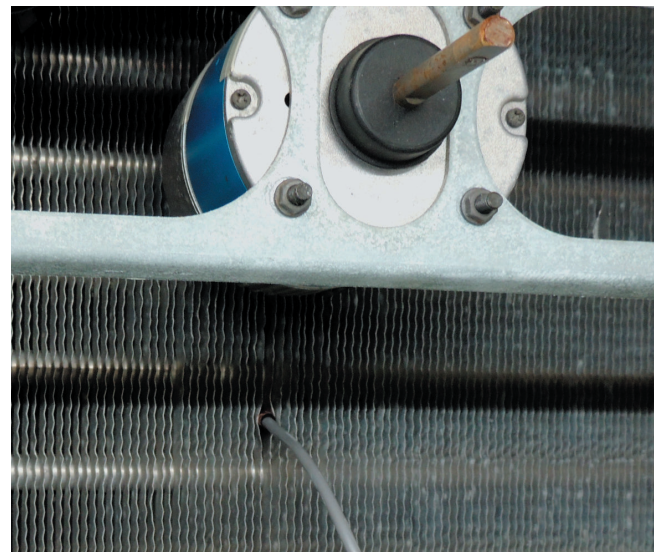

3a. Connect the Evaporator Coil Ice Sensor to terminals ICE1 & GND per the wiring diagram on Page 7.

Installation Con't

INSTALLATION TIP:

Place your fingers behind the 759-ECM circuit board to support the board while plugging the quick connect sensor wires into the terminals for the best connection as shown below.

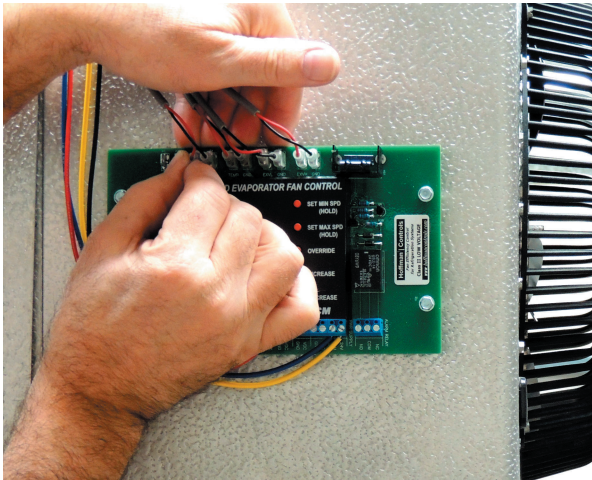

- 3b. If there is a second Evaporator Coil on the same Compressor circuit, a second Evaporator Coil Ice Sensor can be installed on the second evaporator coil using the same procedure in step (3.) above. Connect the second Ice Sensor to terminals ICE2 & GND per the wiring diagram Page 7.
4. An external 24Vac(+20%/-10%), 4VA power source is required to power the 759-ECM Controller. The 24Vac power source can be any 24Vac supply for Cooler/Medium Temperature applications that do not require defrost. For Freezer applications, the 24Vac power source must be derived from the evaporator fan motor(s) line voltage power source to ensure that the Controller 24Vac power source and fan motor(s) are shut off during the defrost cycle. A 24Vac/12VA Transformer Installation Kit p/n 500-0041-059 with 18AWG wire is available for easy installation and is shown below.

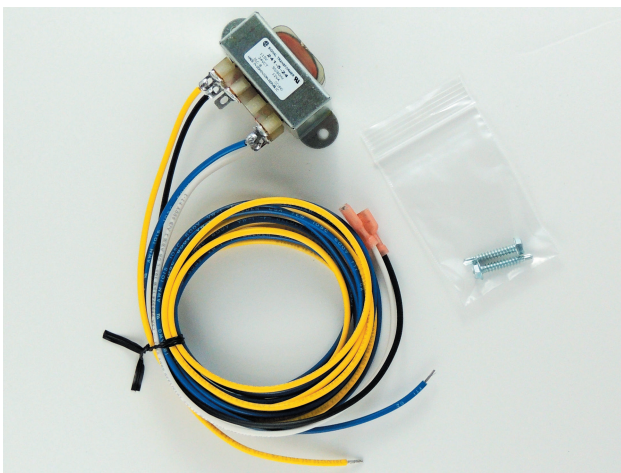

Installation Con't

- 4a. For typical Cooler or Freezer installations, the best way to create a 24Vac power source is to use the Evaporator fan motor 115Vac line voltage power strip and a 115Vac to 24Vac, minimum 4VA transformer or the 24Vac/12VA transformer installation kit as shown below.

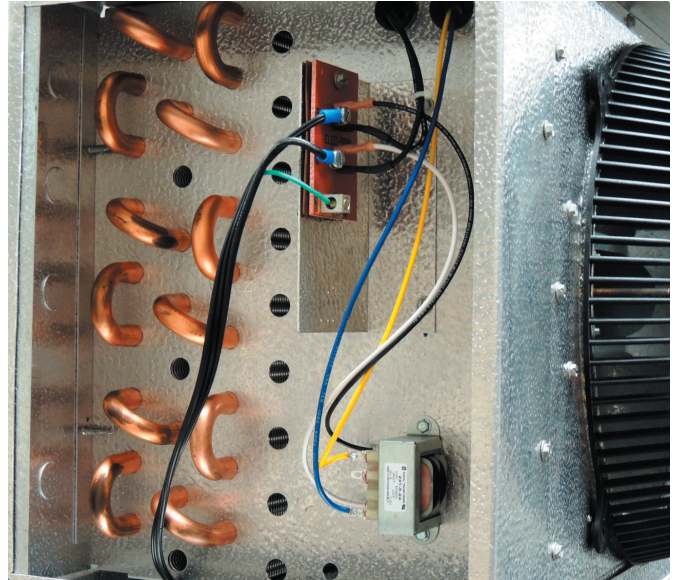

- 4b. Connect the 24Vac power supply to terminals 24V & COM per the wiring diagram on Page 7.
5. Determine from the ECM motor manufacturers specifications and wiring diagram the type of control signal the motor uses to vary the motor speed. The ECM motor must use a PWM, 0-10Vdc or 10-0Vdc control signal to be compatible with the 759-ECM Controller. Hoffman Controls offers a 1/15HP, 115Vac, 500-1800RPM, CCW ECM motor p/n 520-1800-759 that has a compatible 3.3-10Vdc control signal and includes a Wiring Kit as shown below.



Installation Con't

5a. It may be necessary to remove the fan motor and mounting bracket from the evaporator to replace the shaded pole motor with the new ECM motor. Mount the ECM motor with the wire harness in the down position. Connect the ECM motor speed control signal negative (-) WHT wire and positive (+) BLK wire leads to the supplied or any 18AWG wire and connect to the control negative (-) and positive (+) PWM or Vdc terminals per wiring diagram on Page 7. Ensure that PWM type motors are connected to the control PWM terminal blocks and Vdc motors to the Vdc terminals.



5b. Note that when installing multiple ECM motors in the same evaporator, the speed control signal wires may be daisy chained from one motor to the next and then run to the control PWM or Vdc terminal blocks as shown below or each motor can be directly connected to the control terminal blocks. Note that there are four PWM and four VDC terminals to allow multiple ECM motors to be connected. Also, you can connect up to three motors on one terminal block. Any combination of PWM and Vdc motors can be used up to 12 motors. Use whichever method is easiest.

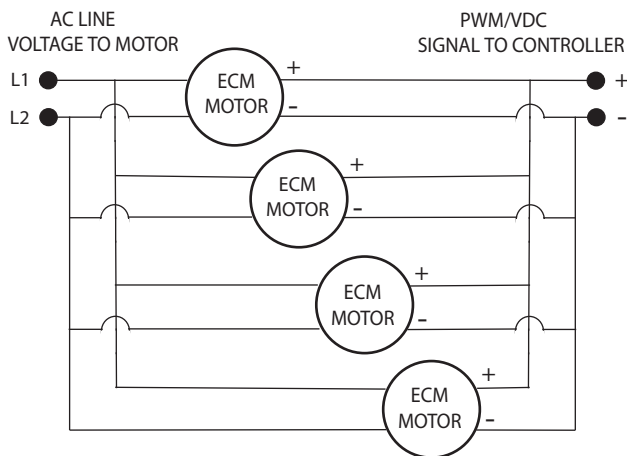

Installation Con't

5c. Connect the ECM motor line voltage leads to the same leads that the shaded pole motor line voltage leads were connected to using the supplied male 1/4" crimp connectors or cut, strip the wire and use wire nuts.

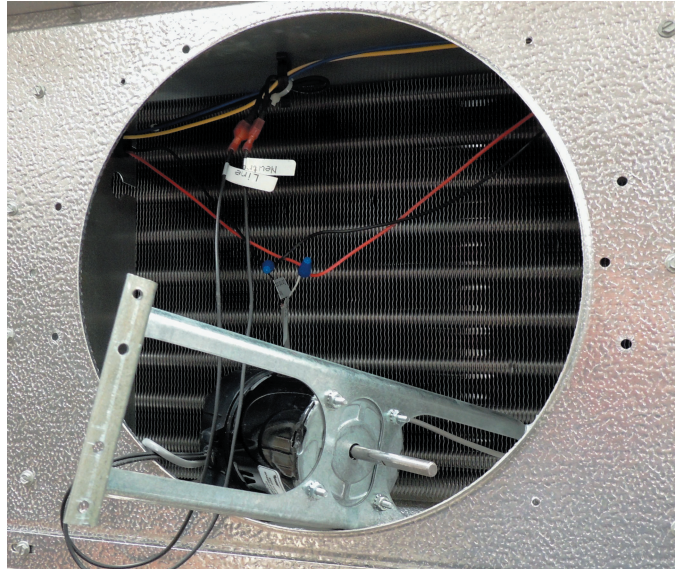

6. An optional alarm relay COM, NC or NO switch contacts are available to turn on an external alarm and/or alarm light. When the 759 Controller has a **Red** fault LED on, the COM and NO contacts are shorted/closed. When no **Red** fault LED is on, COM and NC contacts are shorted/closed. The alarm relay contacts are rated for 24V@10A and are connected per the wiring diagram on Page 7.

7. An optional compressor "ON" signal input is available on the 759 Controller. Although this Controller can detect the ON/OFF status of the compressor using the expansion valve High and Low Pressure Side temperature sensors, some users may prefer to run a direct line from the thermostat or compressor to the Controller to identify compressor ON/OFF status. A 24Vac signal can be derived from the thermostat compressor control signal or from the compressor "ON" contactor. The Controller will accept this 24Vac signal to indicate the compressor ON/OFF status. Connect this COMPRESSOR ON SIGNAL per the wiring diagram on Page 7. When this method is used, the two expansion valve sensors do not need to be used and the **Red** "CHECK EXP VALVE SENSORS" LED will not illuminate.

Checkout Procedure



WARNING

Check all 759-ECM Controller, ECM motor, Evaporator and Compressor wiring prior to applying power.

1. Apply power to the system including the evaporator, fan motor(s) and 759-ECM Controller. The **NORMAL OPERATION** and **COMPRESSOR IS ON Green** LEDs should be on and the fan motor(s) should run at full speed. If not, check for wiring errors. If any of the Check Sensor fault LED's are on, check the sensor wiring. **Note** that the Controller is set at the factory for 0-10Vdc/PWM operation. If you are using 10-0Vdc fan motor(s) they will be running at minimum speed until step (1a.) is completed.

The Controller is now set for normal operation.

- 1a. If the fan motor(s) are 10-0Vdc type motors, they should be running at minimum speed and you will need to change to the 10-0Vdc operating mode by holding down the **SET MIN, SET MAX, INCREASE** and **DECREASE** buttons at the same time for at least 1/2 second. The LEDs will light from top to bottom indicating 10-0Vdc operation. The fan motor(s) should now be running at full speed.
- 1b. Motor minimum and maximum speeds can be set to desired levels by using the **SET** buttons in conjunction with the **INCREASE/DECREASE** buttons. The factory defaults are 1.0Vdc or 10%PWM (minimum speed) and 9.9Vdc or 99%PWM (maximum speed). To set minimum speed, press and hold the **SET MIN SPEED** button while pressing the **INCREASE** or **DECREASE** button. To set maximum speed, press and hold the **SET MAX SPEED** button while pressing the **INCREASE** or **DECREASE** button. The **OVERRIDE IS ON Red** LED will flash during this process. Note that the factory speed defaults can be reset by pressing both the **SET MIN SPEED** and **SET MAX SPEED** simultaneously and then releasing. All LED's will turn on during this speed reset process.
2. An **OVERRIDE** button is provided to override the Controller operation and cause the fan motor(s) to run at full speed at all times. Press and release the **OVERRIDE** button to enter the override mode. The **Red OVERRIDE IS ON** LED will be on and the **Green NORMAL OPERATION** LED will be off. Press and release the **OVERRIDE** button again to exit the override mode. Should the Controller be in the **OVERRIDE** mode and power is cut off and then turned back on, the Controller will still be in the **OVERRIDE** mode.
3. The installer should verify the Controller is tracking the compressor cycle by watching the **Green COMPRESSOR IS ON** LED. When the compressor is on, the LED should be on. When the compressor is off, the LED should be off.

759-ECM Controller Operation

The 759-ECM Refrigeration Evaporator Fan Controller is designed to achieve maximum energy efficiency by using ECM motor technology and by optimizing fan speed throughout the refrigeration cycle. The Controller does not require interfacing with any existing controls or thermostats and instead uses temperature sensors as inputs to directly control the variable-speed features of ECM fan motors for true plug and play energy savings.

Four temperature sensors are used. Two of the sensors monitor the expansion valve and determine compressor on/off state. The other two sensors monitor the temperatures of the vault and coil. These vault and coil temperatures are recorded in memory and continuously monitored during the compressor cycle. The Controller utilizes this information to adjust the control algorithm, optimize evaporator fan speed and maximize the amount of time the compressor is off.

The Controller will self-adapt to any size refrigeration system. There are only two parameters that can be set on the board: the minimum fan speed and the maximum fan speed. These are adjusted using pushbuttons on the control while observing the desired fan speeds. These parameters are stored in flash memory so that they can be recalled after a power interruption.

The Controller includes an override button that allows an operator to place the system in high fan speed mode until the operator chooses to remove the override.

The system can also detect the presence of ice when used in a mid-temperature cooler environment and if ice is still present after 75% of the compressor off cycle, the fans will go to high speed to remove the frost. If instead the system is operating in a low temperature freezer mode, the ice detectors will not be used. When the freezer enters a defrost cycle, the power to the Controller and fans will be cut off by the existing thermostat.

The Controller includes a dry contract relay that can be used to trigger a remote alarm/light if desired. The board will alarm on override or if any of the required temperature sensors are out of range. A series of LEDs on the board are used to indicate the state of the control and the sensors. If the Controller detects an error in critical sensors, the problem will be indicated and the fans will operate at high speed until the issue is corrected.

All ECM motors that accept PWM or a DC voltage can be controlled, including those that use a fail safe decreasing voltage for increasing fan speed (10-0Vdc) in order to guarantee a high speed for the fan motors if the control should lose power or connection to the fans.

The Controller offers a direct line compressor state 24Vac input that can be derived from the thermostat or compressor to indicate when the compressor on/off state. If this is used, then the two temperature sensors on both sides of the expansion valve do not need to be used.

Operational Settings

USING THE OVERRIDE BUTTON:

The 759-ECM Controller includes an **OVERRIDE BUTTON** that allows an operator to override the normal operation of the Controller and force the evaporator fan motor(s) to full speed. This operating mode can be used to test the fan motor(s) at full speed or can be used in an emergency until maintenance can be performed.

To enter the override mode, press the **OVERRIDE BUTTON** once and release. The **Red OVERRIDE IS ON** LED will illuminate. The ALARM RELAY will energize and the COM and NO contacts will close to activate an external alarm system. To exit the override mode, press and release the **OVERRIDE BUTTON** once again.

SETTING THE MIN AND MAX FAN SPEED:

Change the **Minimum** fan motor(s) speed by **pressing** and **holding** the **SET MIN SPD** button and using the **INCREASE** or **DECREASE** buttons to change the **Minimum** fan motor(s) speed. The **Green NORMAL OPERATION** LED will flash during this time. Once the desired minimum speed is achieved, release the **SET MIN SPD** button.

Change the **Maximum** fan motor(s) speed by **pressing** and **holding** the **SET MAX SPD** button and using the **INCREASE** or **DECREASE** buttons as per above.

FACTORY MIN/MAX FAN SPEED SETTINGS:

Minimum factory fan speed setting: 10% for PWM type motors and 1.0Vdc for Vdc type motors.

Maximum factory fan speed setting: 99% for PWM type motors and 9.9Vdc for Vdc type motors.

RESET TO FACTORY SETTINGS:

Press the **SET MIN SPD** and **SET MAX SPD** buttons simultaneously until all of the LEDs illuminate and release. This will reset **Minimum** and **Maximum** fan motor speed and the Maximum Compressor "OFF" fan motor speed to factory settings.

Operational Indicators

"OVERRIDE IS ON" INDICATOR:

Anytime the **OVERRIDE BUTTON** is pushed, the **OVERRIDE IS ON Red** LED will illuminate, the fan motor(s) will run full speed and the ALARM RELAY will be energized. No other Controller features will function until the button is pressed again resuming normal operation.

Operational Indicators Con't

"NORMAL OPERATION" INDICATOR:

When the **NORMAL OPERATION Green** LED is illuminated, the Controller is functioning normally. This LED will be off if any of the two **Red** LEDs are illuminated (**OVERRIDE IS ON** or **CHECK EXP VALVE SENSORS**). The Controller will continue to function should any of the three Yellow LED indicators are be illuminated (**ICE DETECTED**, **CHECK ICE SENSOR** or **CHECK VAULT TEMP SENSOR**).

"COMPRESSOR IS ON" INDICATOR:

When the **COMPRESSOR IS ON Green** LED is illuminated, the Controller has detected that the system compressor is on. When this **Green** LED is off, the Controller has determined the system compressor is off.

"ICE DETECTED" INDICATOR:

The Controller can detect the presence of ice when used in Cooler/Medium Temperature applications and if ice is still present after 75% of the compressor off cycle, the **ICE DETECTED Yellow** LED is illuminated and the fan motor(s) will run at full speed to remove the frost. The **Ice Detect** feature is automatically turned off for Freezer applications.

"CHECK ICE SENSOR" INDICATOR:

When the **CHECK ICE SENSOR Yellow** LED is illuminated, the Controller has detected that the ICE1 SENSOR is not connected, opened or failed. The ICE2 SENSOR is not fault protected and if used, the ICE1 fault detection will only work if both sensors fail.

"CHECK VAULT TEMP SENSOR" INDICATOR:

When the **CHECK VAULT TEMP SENSOR Yellow** LED is illuminated, the Controller has detected that the VAULT TEMP SENSOR is not connected, opened or failed. The Controller will continue to operate normally using the last vault temperature cycle information until maintenance can be accomplished.

"CHECK EXP VALVE SENSORS" INDICATOR:

When the **CHECK EXP VALVE TEMP SENSORS Red** LED is illuminated, the Controller has detected that either or both of the EXPANSION VALVE LOW OR HIGH SIDE SENSORS are not connected, opened or failed. The fan motor(s) will run full speed and the ALARM RELAY will be energized. No other Controller features will function until maintenance is completed. This **Red** LED is disabled when using the compressor ON direct line method as described in the installation instruction step (7.), page 4.

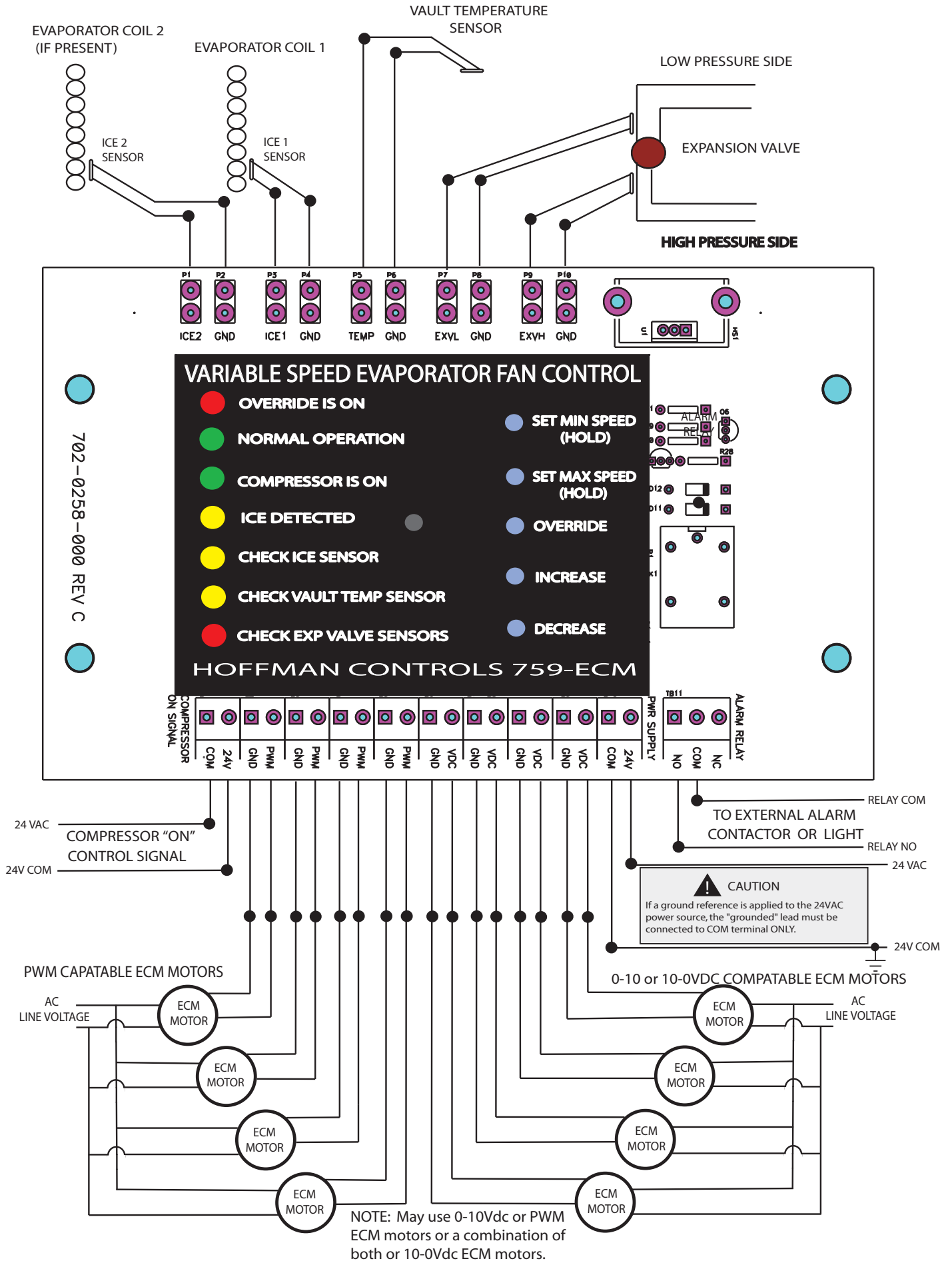

Troubleshooting Guide

Condition	Cause	Solution
Variable Speed ECM Motors Will Not Operate	<ol style="list-style-type: none"> 1. Variable speed ECM Motor not wired correctly. 2. Selected ECM motor is not a continuously variable speed motor. 3. PWM operated ECM motor wired to Vdc output. 4. 0-10 or 10-0 Vdc operated ECM motor wired to PWM output. 5. ECM Motor "OFF" on internal overload. 6. ECM Motor not wired correctly. Controller damaged. 	<ol style="list-style-type: none"> 1. Check wiring, review instructions. 2. Use continuously variable ECM motor. 3. Wire ECM motor to PWM output. 4. Wire ECM motor to Vdc output. 5. Motor protected. 6. Replace Controller.
Variable Speed ECM Motors Will Not Modulate Properly	<ol style="list-style-type: none"> 1. 10-0 VDC operated ECM motor being used. 2. Minimum and/or Maximum speed is incorrect. 3. ECM motor not loaded correctly 4. PWM operated ECM motor being used. 	<ol style="list-style-type: none"> 1. Set Controller for 10-0Vdc operation. 2. Check MIN/MAX speed settings. 3. Use proper fan blade. 4. Use PWM control signal.
Variable Speed ECM Motors Speed/RPM Incorrect	<ol style="list-style-type: none"> 1. 10-0Vdc operation set instead of 0-10Vdc/PWM operation. 2. 0-10Vdc/PWM operation set instead of 10-0Vdc. 3. Minimum speed is too slow or too fast. 4. Maximum speed is too slow or too fast. 	<ol style="list-style-type: none"> 1. Set Controller for 0-10Vdc/PWM operation. 2. Set Controller for 10-0Vdc operation. 3. Set Minimum speed. 4. Set Maximum speed.
Check Sensors LED or LEDs Illuminated	<ol style="list-style-type: none"> 1. Ice Sensor wiring open, broken or bad sensor. 2. Vault Temperature Sensor wiring open, broken or bad sensor. 3. Expansion Valve Sensors wiring open, broken or bad sensor. 	<ol style="list-style-type: none"> 1. Check Ice Sensor wiring/resistance, replace sensor. 2. Check Temp Sensor wiring/resistance, replace sensor. 3. Check EXP Sensors wiring/resistance, replace sensor.
Compressor ON LED Does Not Come On/OFF	<ol style="list-style-type: none"> 1. Expansion Valve Sensors wiring open, broken or bad sensor. 2. System freon charge incorrect. 3. Expansion Valve bad or not operating correctly. 4. Compressor is not running. 	<ol style="list-style-type: none"> 1. Check EXP Sensors wiring/resistance, replace sensor. 2. Check freon charge and correct. 3. Check temperatures across valve, replace. 4. Check freon charge, compressor wiring.

Hoffman|Controls