

Hoffman|Controls

Installation & Operating Instructions

Model 610 Digital Current Monitor



CAUTION:

Failure to read, understand and follow the accompanying instructions and diagrams, prior to completing the installation, may result in permanent damage to the motor.

Introduction

The class II Model 610 Digital Current Monitor offers the latest technology for providing positive and accurate over current motor (load) protection for single, and 3 phase motors, drawing between 5 and 200 amps. The Model 610 also can monitor up to two thermistor temperature sensors to detect abnormally high and/or low compressor operating temperatures.

Motor protection is accomplished by monitoring the operating motor current, in each phase of the load, using current transformers. For both single and 3 phase loads, the control digitally processes the sampled current and calculates the excess energy being absorbed by the motor due to current flow above the operator selected trip level. If the current is above the selected trip level, the controller calculates the excess power and integrates to calculate excess energy. When the excess energy rises to a level equivalent to locked rotor for 2 seconds, a current trip will occur. If the current drops below the trip level prior to a trip, the controller will reset the integration to zero. This prevents false-alarm trips. Fail-safe operation is provided by protecting the load from excessive current or abnormal temperatures in one or more of the following overload conditions:

Electrical Overcurrent	Mechanical Overload
Single & 3 Phase	Wear
Phase Imbalance	Binding
Low/High Voltage	Friction
Locked Rotor	Stall
Power Factor	Torque

Compressor Temperature Abnormalities

High Exhaust Temperature
High and/or Low Oil Temperature

If one of the above conditions occurs, the Model 610 operates a TRIP relay to disconnect power from the load. An ALARM relay is also provided that can be used to alert operators of a lockout condition. The number of automatic trip resets allowed before a lockout occurs is operator selectable. The automatic trip reset time is also selectable.

When protecting 3 phase loads, the Model 610 detects phase

imbalance and can also verify correct phase rotation during each load's startup.

Setting the current trip level at 8% above the nominal FLA of the motor will indirectly provide both low and high voltage protection. Setting the current trip level at other percentage levels above FLA will directly protect the motor.

The optional, customer supplied, Omega 10K thermistor temperature sensors can be used to monitor compressor exhaust temperature and crankcase oil temperature. Omega offers a wide range of thermistor sensors that are readily available. The trip temperature values are operator selectable. The Exhaust high temperature value can be set between 80°F and 300°F or between 100 Ohms and 20K Ohms. The Oil temperature trip values can be set for high, low or both high and low trip temperatures between 20°F and 200°F or between 250 Ohms and 50K Ohms. Consult factory for different temperature ranges.

This micro controller based Model 610 Digital Current Monitor is available in four different models:

- 1) **Model 610-1PH** Provides single phase motor protection
- 2) **Model 610-3PH** Provides three phase or single phase motor protection
- 3) **Model 610-1PH(MOD)** Provides single phase motor protection and Modbus RTU remote operation.
- 4) **Model 610-3PH(MOD)** Provides three phase or single phase motor protection and Modbus RTU remote operation.

All four Model 610 Digital Current Monitor models can be operated locally using the four push buttons and LCD screen. The two Modbus models [ending in (MOD)] can also be operated remotely using a Modbus RTU master controller.

All Model 610 Monitors operate on 24 VAC (2.5 VA).



IMPORTANT:

When using the Model 610 Digital Current Monitor, select a transformer to meet the requirements of all the 24 VAC components being used.

Description

The Model 610 Current Monitor consists of a Kydex covered PCB on standoffs, with a 32 character LCD and four push buttons. The LCD is used to 1) display operational information and 2) for setting parameters and numerical values via a menu system. The menu system allows the operator to:

- 1) Reset a trip
- 2) Select the number of monitored current phases.
- 3) Select the current trip level.

Description Con't

- 4) Activate or de-activate checking phase order on power up.
- 5) Select the % phase imbalance trip level.
- 6) Select the type of exhaust and / or oil temperature sensors used and their trip levels.
- 7) Select the number of automatic trip resets before lockout occurs.
- 8) Select the delay time between automatic reset attempts.
- 9) Select when an external alarm should be activated.
- 10) Select the Modbus settings.
- 11) Restore the control to factory default settings.

During normal operation, all the Model 610 Monitors' LCDs display a Home Screen which shows the following information:

- 1) The present amp draw from the load's phase that is carrying the highest current.
- 2) The present highest sensed temperature value. When both the **Exhaust** and **Oil** sensors are activated, only the sensor that has the highest temperature is displayed.
- 3) The number of automatically reset trips allowed before a lockout occurs.
- 4) The number of automatically reset trips that have occurred since the last lockout occurred, whether triggered locally or remotely.

By pressing the **DOWN** button during normal operation, the LCD will display all three phase currents, in amps, and both sensor temperatures in °F, even when they are not being used (installed) or have not been selected. The unused phase currents and temperature sensor values are displayed as "0".

By pressing the **UP** button during normal operation, the LCD will display the following information about the last trip that occurred:

- 1) The trip type (current, phase imbalance, temp high, temp low, phase order).
- 2) The value that caused the trip, and the time in hours since the last trip occurred (up to 32,000 Hrs.).

During a tripped condition, the LCD will display "TRIPPED". If the trip has resulted in a lockout, then "MANUAL RESET RQD" will be displayed on the LCD.

All the Model 610's have an automatic time out that returns the LCD to the Home Screen whenever the control's push buttons have not been pressed for more than 5 minutes. If the time out occurs before any menu changes have been saved (by pressing the **ENTER** button), the unsaved changes will be ignored.

The Model 610 Digital Current Monitor can be used for local, remote or a combination of both local and remote operation.

During Local (Manual) Operation:

The Model 610 Digital Current Monitor can be operated manually using the four (4) push buttons and LCD screen. The push buttons (**MODE**, **UP**, **DOWN** and **ENTER**) allow the installer to use the LCD's menu system to select the desired mode and then set the available options, parameters and numerical values associated

with that particular mode.

The Model 610 Digital Current Monitor has six (6) modes with each mode containing the specific menus, submenus, parameters and numerical value selections needed to implement that mode's capabilities.

The LCD display routinely shows a Home Screen. The installer can verify or modify the Model 610's operation by pressing the **MODE** button, a specific number of times, to enter the desired mode. After that mode's selected parameters and numeric values have been reviewed or updated, the Model 610's LCD automatically returns to the Home Screen. To continue viewing or updating another mode's parameters, the installer needs to press the **MODE** button the required number of times to enter that mode, as shown in **TABLE 1** (below).

<i>MODE Button Presses</i>	<i>Mode Displayed on LCD</i>
<i>1</i>	<i>Manual Reset</i>
<i>2</i>	<i>Current Trip Settings</i>
<i>3</i>	<i>Temperature Trip settings</i>
<i>4</i>	<i>Trip Auto Reset and Alarm</i>
<i>5</i>	<i>Modbus Settings</i>
<i>6</i>	<i>Reset Controller (to factory settings)</i>

Number of Mode Button Presses

TABLE 1

By pressing the **ENTER** button when one of the above modes is displayed on the LCD's screen, the operator enters that mode's menu and submenu where specific actions can be taken and specific numeric values can be set, using the **UP** and **DOWN** buttons. When that specific menu or submenu's selection is correct, for the application, press the **ENTER** button to save the displayed setting and advance to the next submenu. Once all of the mode's submenus have been displayed, pressing the **ENTER** button one more time returns LCD to the Home Screen. Any values or parameters that are changed are stored in the Model 610's flash memory and will be retained during any power interruption.



IMPORTANT:

After updating any information displayed on the LCD's screen, the installer MUST review ALL of the Model 610 Digital Current Monitor's mode, menu, submenu and numerical value options to 1) ensure that all of the operating parameters, needed for the application, have been correctly selected and 2) also ensure that any unneeded or undesired options or numerical values have not inadvertently been left selected.

During Remote Operation:

Remote operation requires a Modbus version of the Model 610 Digital Current Monitor [models ending in (MOD)] that is connected to a Modbus RTU communication link. A Modbus RTU

Description Con't

Master Computer is used to read and / or write data to all of the internal data registers of each Model 610 connected to the communication link.

Remote operation can be implemented, at any time, by using a Modbus RTU master computer to send the appropriate register data, listed in Table 6A & 6B, on pages 13 & 14, to the Model 610's internal data registers, via a 3 wire Modbus RTU connection. All of the Model 610's options, parameters and numerical values can be read and set remotely using the Modbus RTU connection.

NOTE: Since the Model 610's operation is controlled by the data stored within its internal registers, the Model 610 provides the same identical operation, whether the register data is changed locally (manually) or remotely.

When the Model 610 is equipped with Modbus, all sensed current and temperature values, all trip information, and all settable parameters and numerical values can be remotely viewed and/or updated using a Modbus RTU master computer. The Modbus RTU master computer can read and or write information (data) to each Model 610 connected to Modbus. See the **Modbus RTU Operation** section (page 15) for additional information.



IMPORTANT:

If any of the down loaded Modbus data is incorrect, the Model 610 Digital Current Monitor's microcontroller will change the incorrect data into software selected default values during the Model 610's next operating cycle. Therefore, after updating any data remotely, the operator ***MUST*** allow the Model 610 to operate for a brief time period before reviewing ALL of the data contained in each of the Model 610's 30 register addresses to 1) ensure that all of the operating parameters and numerical values, needed for the application, have been correctly selected and 2) also ensure that any unneeded or undesired options or numerical values have not inadvertently been left selected.

For Both Local and Remote Operation:

A combination of local and remote operation can be used to remotely download and verify any of the Model 610's updated parameters and numerical values. An installer observes local operation after the download, then makes and verifies any further operational improvements, before the register data is uploaded to the remote site and saved for future use.

Installation

1. The Model 610 Digital Current Monitor is designed for use with single phase or three (3) phase motors (across the line or split winding) that draw between 5 and 200 amps.
2. The TRIP and ALARM relays' maximum output ratings are:

24 VAC at 10 Amps each.

3. Wiring must comply with Local and National Electrical Codes.
4. Locked Rotor Amps (LRA) is calculated as 5 times the motor's running (trip) amps.

NOTE:

The Model 610 Digital Current Monitor is not weatherproof and needs to be protected from moisture and condensation.



IMPORTANT:

The TRIP and ALARM relays' N.O. and N.C. terminal names correctly identify the functions of these terminals after 24 VAC power is applied to the Model 610. When 24 VAC power is turned off, the TRIP and ALARM relay's N.O. to COM contact is ***closed*** and the N.C. to COM contact is ***open***. This arrangement was chosen to enable the Model 610 Digital Current Monitor to disconnect power to the motor and enable an alarm in the event that the Model 610 Digital Current Monitor loses power or fails.

5. Do not mount the Model 610 in an airtight cabinet/compartment or on a vibrating surface.
6. Do not mount the low voltage CT wires in the proximity of power wires or wire conduits.



Current Transformer Alignment

Figure 1

Installation Con't

For convenience the CT's black wires may be connected together and a single black wire can be routed to any one of the Model 610's CT terminals.

The Model 610 uses Current Transformers (CTs) to monitor the current flowing through each motor's power wire that is equipped with a current transformer. The CTs are installed as shown in **Figure 1**. When more than one (1) CT is used to monitor motor (load) current, all the installed CTs must be oriented in the same direction, as shown in **Figure 1**, to provide accurate in-phase information.

3 Phase, Across the Line, Motor Installation

1. Disable all line power going to the motor contactor and motor.
2. Disconnect all factory wiring connecting the motor to the load side of the motor contactor.



WARNING:

Disconnect power from the motor(s) and ensure the motor(s) is/are electrically disabled prior to the Model 610 Digital Current Monitor's installation.

3. Refer to **Figure 1** (page 3) to install the three (3) current transformers. Place a single current transformer on each of the three (3) power wires connected to the motor. The sides of the current transformers, with the black text printed on the yellow background, *must* all be pointed in the same direction (CT signals in phase).

4. Re-connect the motor's power wiring, removed in step 2 (above), to the load side of the motor contactor.

5. Referring to **Figure 1** and **Figure 2** (page 5), connect the current transformer's wires to the Model 610 Digital Current Monitor's CT terminals as shown in **Table 1**.

6. Connect 24VAC power, as shown in **Figure 2** "Model 610, 3 Phase Wiring Diagram" (page 5).

7. Connect the TRIP relay's N.C. terminal to a 24 VAC source as shown in **Figure 2**.

8. Connect the TRIP relay's COM terminal to the 24 VAC side of the motor contactor's coil as shown in **Figure 2**.

9. If an alarm notification is desired, connect the alarm's 24 VAC wires to the ALARM relay's N.O. and COM terminals.

10. If compressor temperature sensing or Modbus communication is desired, refer to **Figure 7, Model 610 Exhaust Sensor, Oil Sensor and Modbus Wiring Diagram** (page 13) and the **Compressor Temperature Sensing Information** section (page 14) and / or the Modus Installation section (page 12) for details.

Motor Contactor Load Terminal	CT Wire Color	Model 610 PCB Terminal
T1	White Black	CT1+ CT1-
T2	White Black	CT2+ CT2-
T3	White Black	CT3+ CT3-

3 Phase, Across the Line,
Current Transformer Placement
Table 1



WARNING:

Current Transformer wires must be connected to the Model 610 Digital Current Monitor's terminal block before operation of the motor. The Current Transformers will generate high voltages if the wires are left unconnected (open circuited).

11. This completes the 3 Phase, Across the Line, Motor's 610 Digital Current Monitor's hardware installation. Continue to page 11, **Normal Operation** section.

Single Phase Motor Installation

1. Disable all line power going to the motor contactor and motor.

2. Disconnect all factory wiring connecting the motor to the load side of the motor contactor.

3. Refer to **Figure 1** (page 3) to install the single current transformer (CT) on the power wire connected to the motor. The CT's orientation is not important.

4. Re-connect the motor's power wiring, removed in step 2 (above), to the load side of the motor contactor.

5. Referring to **Figure 3, Model 610 Single Phase Wiring Diagram** (page 6), connect the current transformer's wires to the Model 610 Digital Current Monitor's CT1 terminals as shown in **Table 2** (page 5).

6. Connect 24VAC power as shown in **Figure 3**.

7. Connect the TRIP relay's N.C. terminal to a 24 VAC source as shown in **Figure 3**.

8. Connect the TRIP relay's COM terminal to the 24VAC side of the motor contactor's coil, as shown in **Figure 3**.

9. If an alarm notification is desired connect the alarm's 24

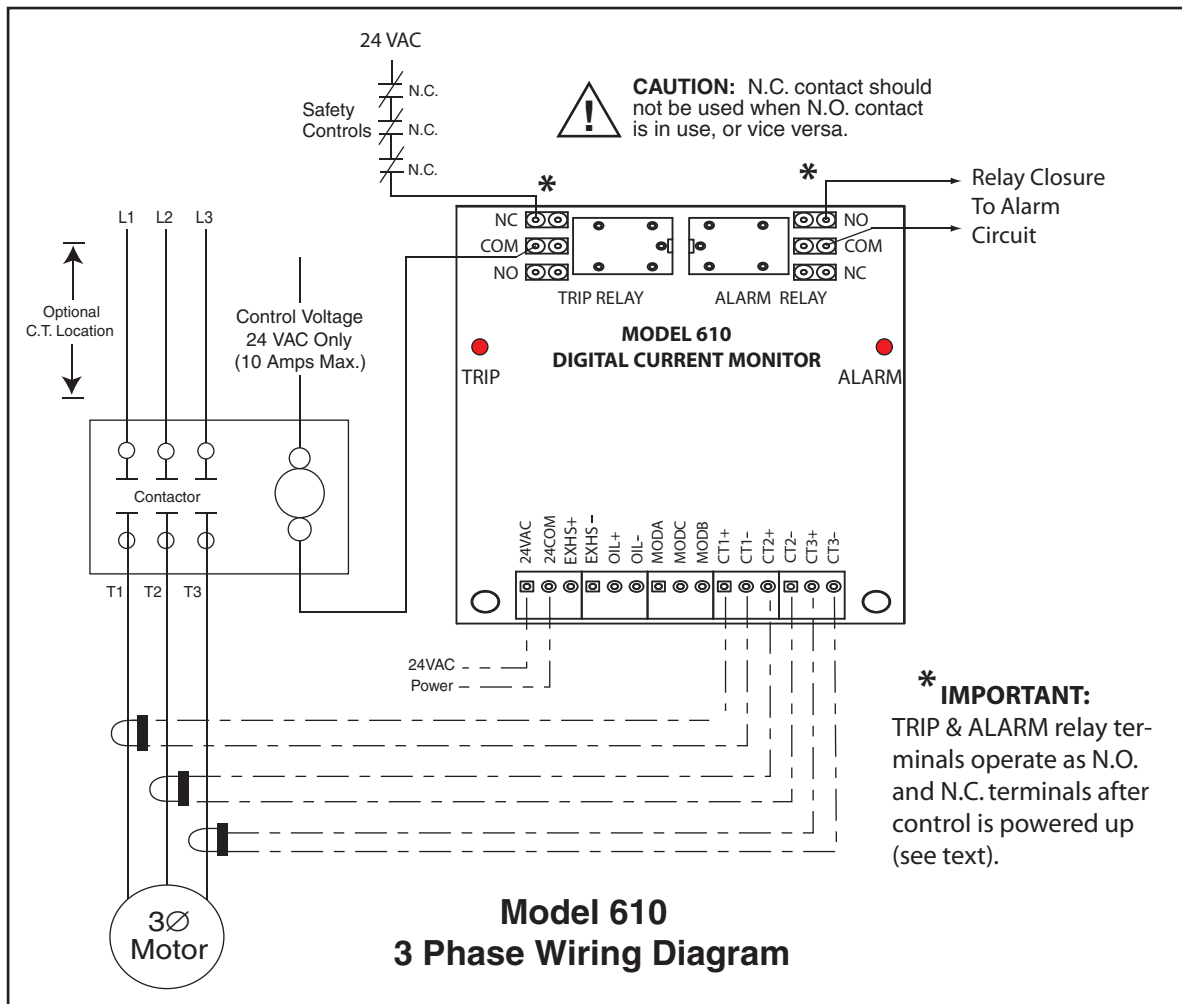

Figure 2

Single Phase Motor Installation Con't

VAC wires to the ALARM relay's N.O. and COM terminals.

Motor Contactor Load Terminal	CT Wire Color	Model 610 PCB Terminal
T1	White Black	CT1+ CT1-

Single Phase Current Transformer Placement

TABLE 2

WARNING:

Current Transformer wires must be connected to the Model 610 Digital Current Monitor's terminal block before operation of the motor. The Current Transformers will generate high voltages if the wires are left unconnected (open circuited).

10. If compressor temperature sensing or Modbus communication is desired, refer to Figure 7, the Model 610 Exhaust Sensor, Oil Sensor and Modbus Wiring Diagram (page 13) and the Compressor Temperature Sensing Information section (page 12) and / or the Modbus Installation section (page 15) for details.

11. This completes the Single Phase Motor's 610 Digital Current Monitor's hardware installation. Continue with the Normal Operation section on page 11.

Part (Split) Winding Motor Information

NOTE:

The Model 610 Digital Current Monitor allows a part (split) winding motor's 2nd circuit to energize for 2 seconds, after power is applied to the 1st split winding circuit, prior to checking for phase rotation errors or phase imbalance issues.

Part (split) winding motors can be protected, using either one (1) or two (2) Model 610 Digital Current Monitors, by following one of the two methods shown below and on the next page:

Method 1: This method uses only one (1) Model 610 monitor by placing two CTs on Starter A phases T1 and T2, and

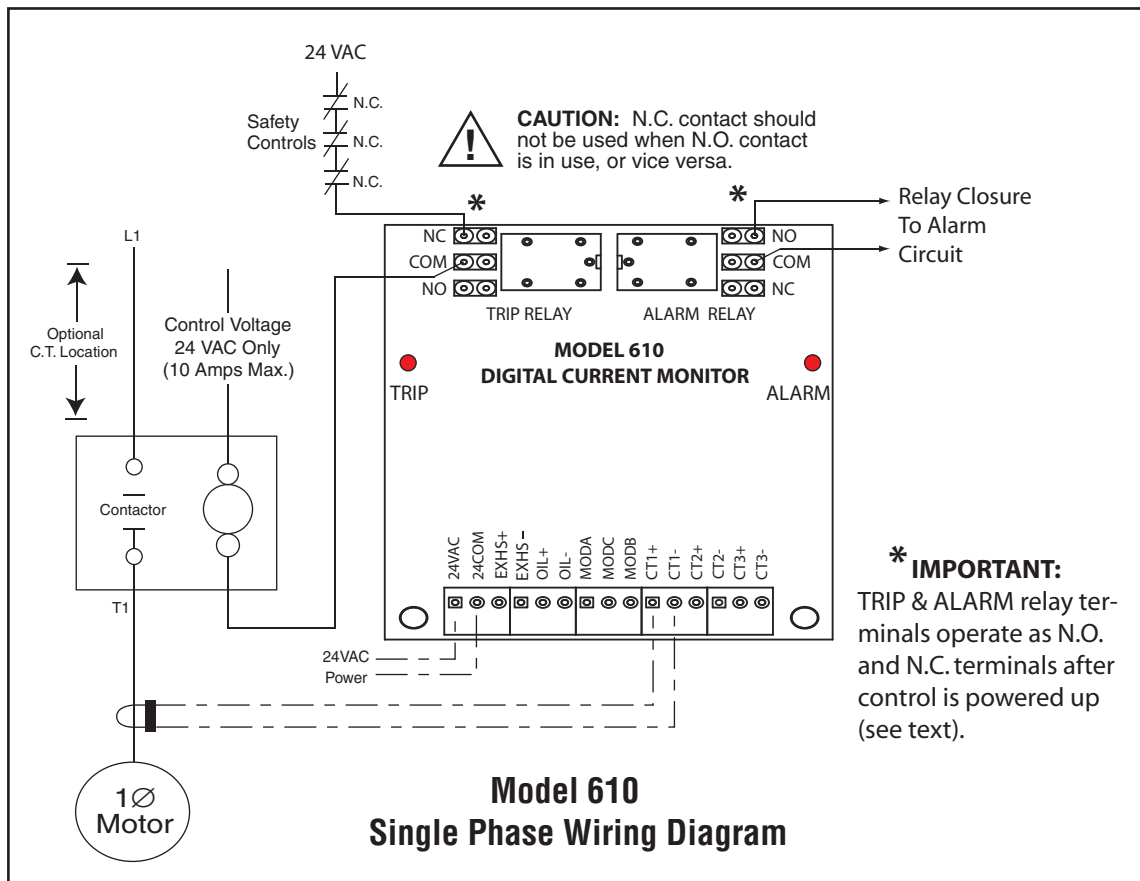

Figure 3

Part (Split) Winding Motor Information Con't

placing the third CT on the Starter B's phase T3. Set the phase imbalance trip point at 29% or more. The current trip level should be the motor FLA times 1.08 (8% about the FLA). This will protect against all major faults in either part winding. However, subtle motor faults such as TBD will not be detected and therefore can not be protected against when only using a single Model 610 Digital Current Monitor.

Method 2: This method uses two (2) Model 610 monitors by placing one (1) CT on each power wire connected to both of the Starter A and Starter B motor contactor's T1, T2 and T3 terminals (total of 6 CTs). The selected trip current level, used by each Model 610, should be 1/2 FLA (the current allowed in each part winding times 1.08 [for 8% over current]).

Single 610 Part (Split) Winding Motor Installation

1. Disable all line power going to both the Starter A and Starter B motor contactors and motor.
2. Disconnect all factory wiring connecting the motor to the load side of the Starter A motor contactor.
3. Refer to Figure 1 (page 3) to install the current transformers. Place a single current transformer on each power wire connected to the motor that was previously connected to the Starter A contactor's load side T1 and T2 terminals.



WARNING:

Disconnect power from the motor(s) and ensure the motor(s) is/are electrically disabled prior to the Model 610 Digital Current Monitor's installation.

4. Re-connect the motor's power wiring, removed in step 2 above, to the load side of the Starter A motor contactor.
5. Disconnect the factory wiring connecting the motor to the T3 terminal on the load side of the Starter B motor contactor.
6. Refer to Figure 1 (page 3) to install a single current transformer on the motor's power wire that was previously connected to the Starter B contactor's load side T3 terminal. Orient this third CT in the same direction as the two (2) CTs on the Starter A phases T1 and T2.
7. Re-connect the motor's power wiring, removed in step 5 above, to the load side of the Starter B motor contactor.
8. Referring to Figure 1 and Figure 4, Single Model 610 Part (Split) Winding Motor Wiring Diagram (page 7), connect the current transformer's wires to the Model 610 Digital Current Monitor's CT terminals as shown in Table 3 on page 7.
9. Connect 24VAC power as shown in Figure 4, "Single Model 610 Part (Split) Winding Motor Wiring Diagram" (page 7).
10. Connect the TRIP relay's N.C. terminal to a 24 VAC source as shown in Figure 4.

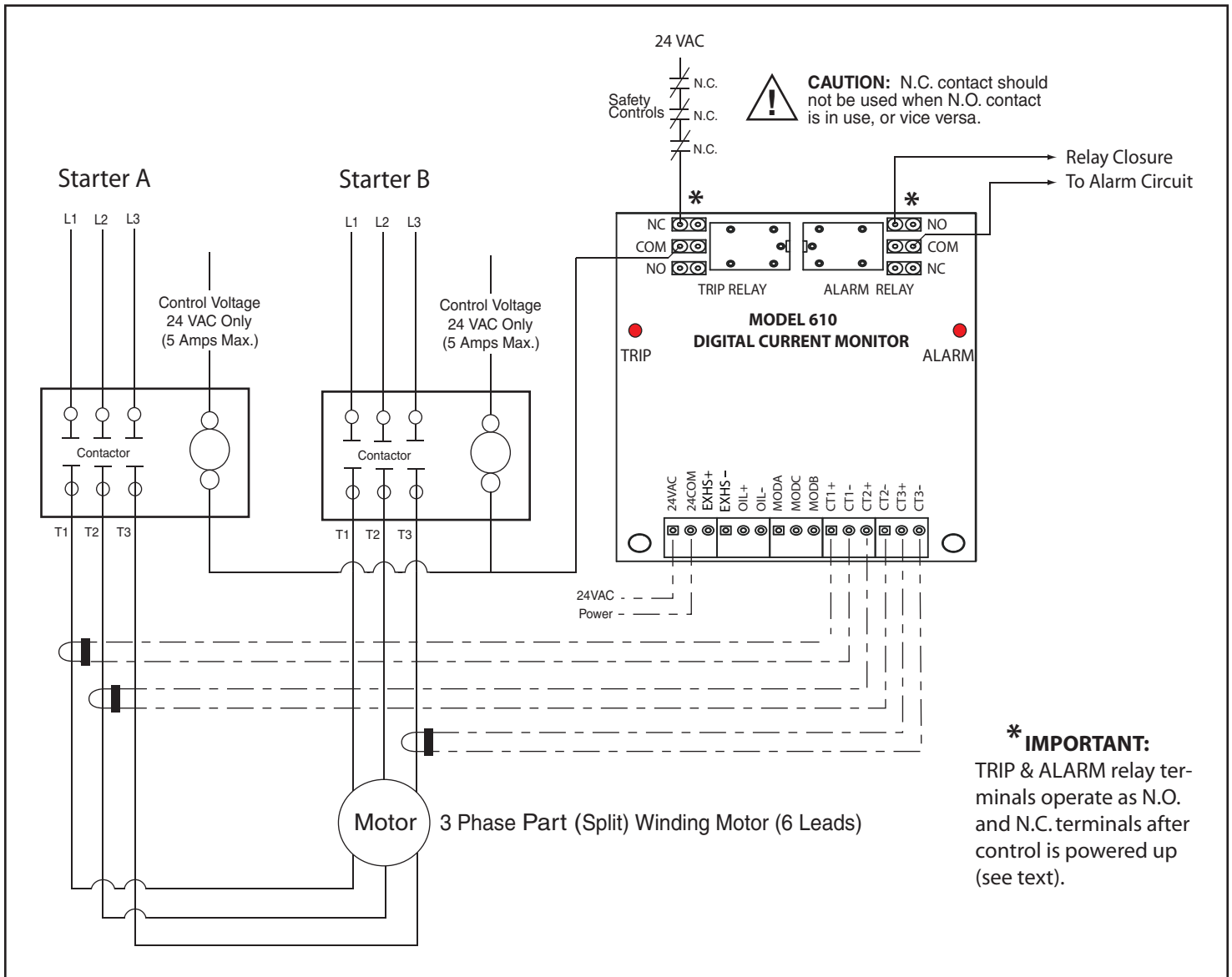

Single Model 610 Part (Split) Winding Motor Wiring Diagram
Figure 4

Single 610, Part (Split) Winding Motor Installation Con't

11. Connect the TRIP relay's COM terminal to the 24VAC side of both the Starter A and Starter B motor contactors' coils as shown in Figure 4.

12. Verify the Starter A and Starter B, 24 VAC, coils are wired in parallel with the Model 610 TRIP relay's COM terminal.

13. If an alarm notification is desired connect the alarm's 24 VAC wires to the ALARM relay's N.O. and COM terminals, as shown in Figure 4.

Motor Contactor		CT Wire Color	Model 610 PCB Terminal
Starter A Terminal	Starter B Terminal		
T1	N/A	White Black	CT1+ CT1-
T2	N/A	White Black	CT2+ CT2-
N/A	T3	White Black	CT3+ CT3-

Single 610, Three Phase Motor Current Transformer Placement
Table 3

Single 610 Part (Split) Winding Motor Installation Con't

16. If compressor temperature sensing or Modbus communication is desired, refer to Figure 7, Model 610 Exhaust Sensor, Oil Sensor and Modbus Wiring Diagram (page 13) and the Compressor Temperature Sensing Information section (page 12) and / or the Modbus Installation section (page 15) for details.

17. This completes the Single 610 Part (Split) Winding Motor's Model 610 Digital Current Monitor's hardware installation. Continue with the Normal Operation section on page 11.

Dual 610 Part (Split) Winding Motor Installation

1. Disable all line power going to the Starter A and Starter B motor contactors and split winding motor.

2. Disconnect all factory wiring connecting the motor to the load side of the Starter A motor contactor.



WARNING:

Disconnect power from the motor(s) and ensure the motor(s) is/are electrically disabled prior to the Model 610 Digital Current Monitor's installation.

3. Refer to Figure 1 (page 3) to place one (1) current transformer on each of the power wires connected to the motor that were previously connected to the Starter A contactor's load side terminals T1, T2 and T3.

4. Referring to Figure 5, Dual Model 610 Part (Split) Winding Motor Wiring Diagram (page 9). Connect each of the current transformer's wires to the # 1 Model 610 Digital Current Monitor's CT terminals as shown in Table 4 (below).

Motor Contactor		CT Wire Color	#1 Model 610 PCB Terminal
Starter A Terminal	Starter B Terminal		
T1	N/A	White Black	CT1+ CT1-
T2	N/A	White Black	CT2+ CT2-
T3	N/A	White Black	CT3+ CT3-

Dual 610 Part (Split) Winding Motor Starter A Current Transformer Placement

TABLE 4

5. Re-connect the motor's power wiring, removed in step 2 above, to the load side of the Starter A motor contactor.



WARNING:

Current Transformer wires **must** be connected to the Model 610 Digital Current Monitor's terminal block before operation of the motor. The Current Transformers will generate high voltages if the wires are left unconnected (open circuited).

6. Disconnect all factory wiring connecting the motor to the load side of the Starter B motor contactor.

7. Refer to Figure 1 (page 3) to place three current transformers, one (1) current transformer on each of the power wires connected to the motor that were previously connected to the Starter B contactor's load side terminals T1, T2 and T3.

8. Re-connect the motor's power wiring, removed in step 6 above, to the load side of the Starter B motor contactor.

9. Referring to Figure 5, connect the current transformer's wires to the # 2 Model 610 Digital Current Monitor's CT terminals as shown in Table 5 (below).

Motor Contactor		CT Wire Color	#2 Model 610 PCB Terminal
Starter A Terminal	Starter B Terminal		
N/A	T1	White Black	CT1+ CT1-
N/A	T2	White Black	CT2+ CT2-
N/A	T3	White Black	CT3+ CT3-

Dual 610 Part (Split) Winding Motor Starter B Current Transformer Placement

TABLE 5

10. Connect 24 VAC power as shown in Figure 5, "Dual Model 610 Part (Split) Winding Motor Wiring Diagram" (page 9) to both the #1 and #2 Model 610's.

11. Connect a 24 VAC source to the #2 Model 610 TRIP relay's N.C. terminal, as shown in Figure 5.

12. Connect the #2 Model 610 TRIP relay's COM terminal to the #1 Model 610 TRIP relay's N.C. terminal, as shown in Figure 5.

13. Connect the TRIP relay's COM terminal, on the #1 Model 610, to the 24 VAC side of *both* the Starter A and Starter B motor contactors' coils as shown in Figure 5.

14. Verify the Starter A and Starter B motor contactors' coils are wired in parallel to the #1 Model 610 TRIP relay's COM terminal.

15. If an alarm notification is desired, refer to Figure 5 and:

1. Connect the alarm's 24 VAC wire to the N.O. terminals on *both* the #1 and #2 Model 610's ALARM relays.

Continued on page 11

HOME SCREEN
 AMPS: 0 EXH: 204
 TRIPS: 0 MAX: 3

MODE Button
 For Manual Reset Press Enter

DOWN Button
 A 0 B 0 C 0
 E: 204 OL: 55

MODE Button
 Current Trip Settings

UP Button
 Last Trip: Current
 175 Amps 0 Hr Ago

OR
 UP Button
 Last Trip: Exhaust
 235 Deg F 0 Hr Ago

- RESETTING TRIP
- Number of Phases
 - Single Phase
 - 3 Phase
 - 0 Phase; Tmp Only
 - Set Trip Level
 - In Amps: 1.0 (Range = 1.0 - 200 amps)
 - Phase Imbalance
 - Allowed: 30% (Range = 2% - 100%)
 - Check Phase Order?: Yes
 - No
 - Go To Home Screen

LINE TYPE LEGEND

MODE Button Press Represented By
 →

ENTER Button Press Represented By
 ••••••••

UP or DOWN Button Press Represented By
 - - - - -

MODE Button
 Temperature Trip Settings

- Use Exhaust Tmp?
 - No
 - Yes
- Use Oil Temp?
 - No
 - Yes
- Oil Sensor Type
 - Omega 10K
- Oil Temp Trips On?
 - High
 - Low
 - Both
- Exh Sensor Type
 - Omega 10K
 - Exhaust Temp Value degF 0
 - Range = 80°F -300°F
 - PTC
 - Exhaust Temp Value Ohms 200
 - Range = 100 Ohms -20.0K
 - NTC
 - Exhaust Temp Value Ohms 200
 - Range = 100 Ohms -20.0K
 - Go To Home Screen
 - Set Oil High Trip degF 200
 - Range = 20°F -200°F
 - Set Oil Low Trip degF 000
 - Range = 20°F -200°F
 - PTC - PosTempCoef
 - Oil Temp Trips On?
 - High
 - Low
 - Both
 - Go To Home Screen
 - NTC - NegTempCoef
 - Same Flowchart as PTC-PosTempCoef Above. Just Uses A Negative Temp Coef
 - Set Oil High Trip Ohms 200
 - Range = 250 Ohms -50.0K Ohms
 - Set Oil Low Trip Ohms 000
 - Range = 250 Ohms -50.0K Ohms
 - Go To Home Screen

MODE Button Press
 Modbus Settings

MODE Button Press
 Trip Auto Reset and All

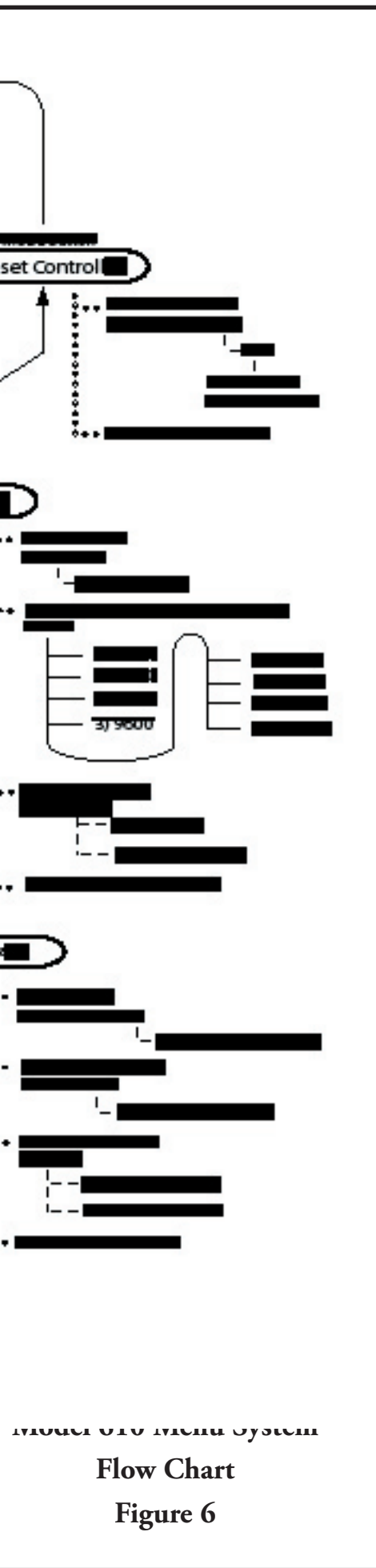

Dual 610, Part (Split) Winding Motor Installation Con't

2. Connect the alarm's 24 VAC RTN wire to the COM terminals on *both* the #1 and #2 Model 610's ALARM relays.
3. Verify the alarm's 24 VAC wire is connected in parallel to *both* the #1 and #2 Model 610 ALARM relay's N.O. terminals.
4. Verify the alarm's 24 VAC RTN wire is connected in parallel to *both* the #1 and #2 Model 610 ALARM relay's COM terminals.
16. If compressor temperature sensing or Modbus communication is desired, refer to **Figure 7, Model 610 Exhaust Sensor, Oil Sensor and Modbus Wiring Diagram** (page 13) and the **Compressor Temperature Sensing Information** section (page 12) and / or the **Modbus Installation** section (page 15) for details.
17. This completes the Dual 610 Part (Split) Winding Motor's hardware installation. Continue with the **Normal Operation** section below.

Normal Operation

During Current Monitoring

The controller will consistently display the Home Screen on the LCD showing the highest phase's current, in amps, and the highest temperature in °F (when used). Also shown is the number of trips that have been automatically reset since the last manual reset occurred, due to either an over current condition or an abnormal temperature value.

By pressing and holding down one of the buttons shown below, while the Home Screen is present on the LCD, the following information will be displayed on the LCD:

DOWN button - Displays the current in each of the three (3) load's phases and the two (2) temperature sensors, even when they are not installed or have not been selected. Unused or unselected current and temperature sensor inputs are shown as "0".

UP button - Displays the last automatically reset trip, including the type of trip, the trip value, and the time since that trip occurred (in hours).

The current value that is displayed on the Home Screen represents the maximum current presently being sensed in the CTs and is used for the over current trip calculation.

Phase imbalance and phase order trips do not occur until the situation has existed for a minimum of two seconds to allow the 2nd winding, on a split winding motor application, to power up.

NOTE:

A current above the trip point will not immediately cause the controller to trip. Only when the integrated excess power, over time, has exceeded the equivalent to a locked rotor for 2 seconds will the trip occur. If the over current drops below the trip value, during the excess power calculation, the controller resets the excess power calculator to zero, thus avoiding nuisance trips. If a different trip integration time is desired, consult the factory.

During Temperature Monitoring

If an exhaust temperature or oil temperature sensor is being used and the Model 610 detects a bad temperature reading, a trip occurs and EXHAUST_BAD or OIL_BAD is displayed on the LCD's screen.

Temperature trips, due to out of range sensor temperatures (either below a low temperature trip value or above a high temperature trip value) occur immediately when the sensed temperature reaches the trip value.

Normal Operation Con't

When a temperature trip occurs that will be automatically reset, the LCD displays the type of trip (EXHAUST or OIL) and the time in minutes until that trip will be reset. If desired, the operator can manually reset the trip, during this automatic reset time, by pressing and releasing the MODE button until the LCD screen displays the "For Manual Reset Press Enter" message and then pressing the ENTER button once.

If the controller has the Modbus option, then a command to manually reset the controller, as well as a command to trip the controller, can be sent remotely over the Modbus RTU connection using address registers 16 and 18 respectively.

The operator can always check the trip level values and all the other Model 610 Digital Current Monitor's parameters, by using the menu system as described in the **Sequence of Operation** section (pages 16 thru 18) or using the Modbus RTU connection to read the Model 610's internal register data, using the **TABLE 6A** and **6B** information on pages 13 & 14.

Compressor Temperature Sensing Information

The Model 610 Digital Current Monitor is designed to work with virtually all thermistor type temperature sensors. However, due to the many differences in compressor types and sizes along with the large availability of Omega thermistor temperature sensors, Hoffman Controls does not offer a temperature sensor as an option for the Model 610 Digital Current Monitor.

The Omega Company manufactures a readily available variety of R - T (resistance - temperature) sensors with different temperature ranges, sensor mounting configurations and wire lengths. Other manufactures also offer R - T style temperature sensors. However, these sensors can have very different temperature resistance scales. Therefore, the Model 610 Digital Current Monitor is designed to work with the Omega 10K linear R - T thermistor temperature sensor family, as well as other sensor manufacturer's extremely fast (steep slope) R - T style temperature sensors.

The Model 610's Exhaust and Oil temperature sensor menu options include the **Omega 10K**, and steep slope PTC and NTC type R - T thermistor sensors. The PTC (Positive Temperature Coefficient) or NTC (Negative Temperature Coefficient) options are selected when a steep slope R - T temperature sensor is used.

When the **Omega 10K** sensor option is selected, the installer sets the trip temperature in °F. When either the PTC or NTC sensor options are selected, the installer enters the trip temperature as the steep slope sensor's trip resistance in ohms. For example:

If a PTC steep slope, R - T temperature sensor with a trip resistance of 15K, at the desired trip temperature is used, the installer would select the PTC sensor option, press the ENTER button and then use the UP and / or DOWN buttons to select 15000 ohms.

Refer to the **Sequence of Operation** section, paragraph numbers 8 thru 31 (page 16) for the **Omega10K**, PTC and NTC operating details.

Exhaust Temperature Sensor Installation

1. Select a temperature sensor mounting configuration that provides a safe and reliable temperature signal for the application. Always select a temperature sensor that exceeds the highest expected compressor discharge temperature. When available, select a wire length longer than required for the application.

2. If additional wire is needed, use 22AWG (minimum) stranded, twisted pair cable properly insulated for the application. The maximum length of additional wire is 75 feet.

3. Follow the exhaust temperature sensor manufacturer's instructions and recommendations when installing the exhaust sensor on the compressor's discharge line.

4. After securely mounting the sensor, refer to **Figure 7, Model 610 Exhaust Sensor, Oil Sensor and Modbus Wiring Diagram**, (page 13) to connect the exhaust sensor's wires to the EXHS+ and EXHS- terminals on the Model 610. Either exhaust sensor wire can be connected to either EXHS terminal.

5) When using two (2) Model 610 Digital Current Monitors for the Dual Model 610 Split Winding Motor installation, wire the exhaust sensor wires to *either* of the #1 and #2 Model 610 EXHS+ and EXHS- terminals.

NOTE: In this case, the #1 and #2 Model 610's Modbus RTU addresses will be different. Therefore, *both* the #1 and #2 Model 610's register data **must** be identical.

6) Refer to the **Sequence of Operation** section, steps 8 thru 13 for selecting the exhaust sensor's temperature trip value.

7. This completes the Model 610's exhaust sensor hardware installation.

Oil Temperature Sensor Installation

1. The Omega temperature sensors are available with a variety of different temperature ranges, sensor mounting configurations and wire lengths. Select a mounting configuration that provides a safe and reliable temperature signal. Always select a temperature sensor that exceeds the highest and lowest expected oil temperature(s). When available, select a wire length longer than required for the application.

2. If additional wire is needed, use 22AWG (minimum) stranded, twisted pair cable properly insulated for the application. The maximum length of additional wire is 75 feet.

3. Follow the oil temperature sensor manufacturer's instructions and recommendations when installing the oil sensor on / in the compressor's crankcase.

4. After mounting the sensor, refer to **Figure 7, Model 610 Exhaust Sensor, Oil Sensor and Modbus Wiring Diagram**, to connect the oil sensor's wires to the OIL+ and OIL- terminals on the Model 610. Either sensor wire can be connected to either OIL terminal.

Continued on page 15

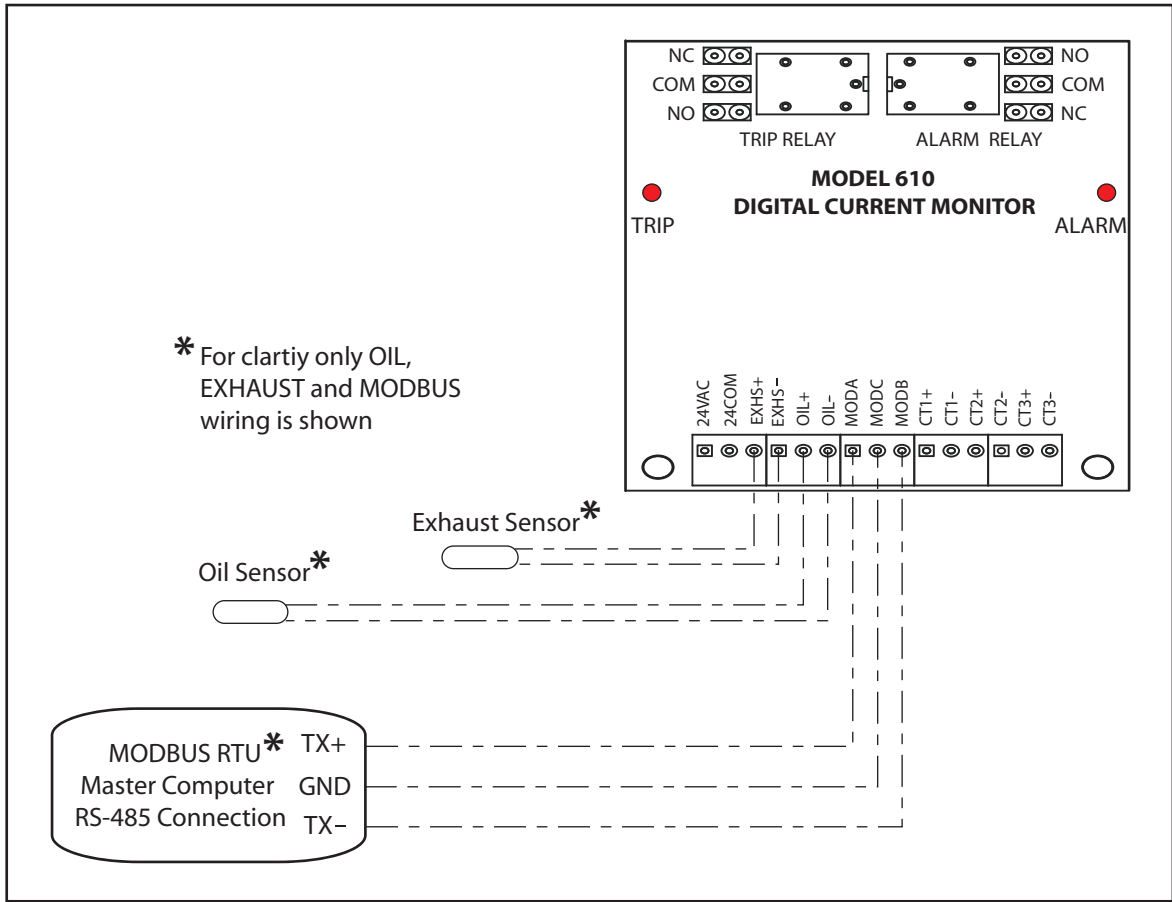

**Model 610 Exhaust Sensor,
Oil Sensor and Modbus Wiring Diagram
Figure 7**

MODBUS RTU ADDRESS	DATA CONTENTS	DATA TYPE and RANGE
0	Trip Amps Times 10	Read & Write; Range = 1 to 200 Amps (All values times 10)
1	Number Of Current Transformers Used	Read & Write; Codes: 1 = Single Phase; 3 = Three Phase; 0 = Temperature Only, No Current Transformers Used.
2	Phase Imbalance Trip % (3 Phase Only)	Read & Write; Range = 1% to 100%
3	Check Phase Order (3 Phase Only)	Read & Write; 1 = Yes or 0= No
4	Auto Reset Delay Time	Read & Write; Range = 0 to 255 Minutes.
5	Use Exhaust Temperature Sensor	Read & Write; 1 = Yes or 0= No
6	Exhaust Sensor Type	Read & Write; Codes: 0 = Omega 10K; 1 = PTC Resistance; 2 = NTC Resistance.
7	Exhaust Trip Temp Value	Read & Write; Range = 80°F to 300°F or 100 Ohms to 20K Ohms Depending on Sensor Type (All values times 10).
8	Use Oil Temp	Read & Write; 1 = Yes or 0 = No
9	Oil Sensor Type	Read & Write; Codes: 0 = Omega 10K; 1 = PTC Resistance; 2 = NTC Resistance.
10	Oil High Temp Trip Value	Read & Write; Range = 0 or 20°F to 200°F or 250 Ohms to 50K Ohms Depending on Sensor Type; 0 is Used When High Temp Not Selected.

**Model 610 Modbus Register Data Information
TABLE 6A**

MODBUS RTU ADDRESS	DATA CONTENTS	DATA TYPE and RANGE
11	Oil Low Temp Trip Value	Read & Write; Range = 000 or 20°F to 200°F or 250 Ohms to 50K Ohms Depending on Sensor Type; 000 is Used When Low Temp Not Selected
12	Max Number Of Auto Resettable Trips Allowed Before a Lockout Occurs	Read & Write; Range = 0 to 255 Trips.
13	Modbus Address Number	Read & Write; Range = 1 to 247.
14	Modbus Baud Rate Code	Read & Write; Baud Rate Codes: 0 = 1200; 1 = 2400; 2 = 4800, 3 = 9600; 4 = 19,200; 5 = 38,400; 6 = 57,600; 7 = 115,200
15	Modbus Parity Code	Read & Write; Parity Codes are: 38 = Even Parity, With 1 Stop Bit. 54 = Odd Parity, With 1 Stop Bit. 14 = No Parity With 2 Stop Bits.
16	Manual Reset Required	Read & Write; 1 = Yes or 0 = No.
17	External Alarm Type	Read & Write; Codes: 0 = Alarm on Every Trip; 1 = Alarm When Lockout Occurs; 2 = Alarm When a Trip Occurs After the Previous Lockout Has Been Reset.
18	Issue Manual Reset	Write Only; 1 = Yes or 0 = No
19	Number of Trips Since Last Manual Reset	Read Only; Range = 0 to Maximum Selected Number Of Auto-Resettable Trips.
20	Current In Phase A	Read Only; Range = 0 to 440 Amps (All values times 10)
21	Current In Phase B	Read Only; Range = 0 to 440 Amps (All values times 10)
22	Current In Phase C	Read Only; Range = 0 to 440 Amps (All values times 10)
23	Present Exhaust Temperature	Read Only; Range = 80°F to 300°F (All values times 10)
24	Present Oil Temperature	Read Only; Range = 20°F to 200°F (All values times 10)
25	Last Trip Type	Read Only; Codes: 0 = None; 1 = Current; 2 = Phase Imbalance; 3 = Exhaust Temp High; 4 = Oil Temp High; 5 = Modbus Initiated Trip; 6 = Phase Order Incorrect; 7 = Oil Temp Low; 8 = Exhaust Sensor Bad; 9 = Oil Sensor Bad.
26	Last Trip Value	Read Only; Units in Amps, or % Phase Imbalance, or °F (All values times 10).
27	Time Since Last Trip	Read Only; Range = 0 to 32,000 Hours.
28	Monitor Tripped	Read Only; 1 = Yes or 0 = No.
29	Time Until Trip Will Auto Reset	Read Only; Range = 0 to 255 Minutes

Model 610 Modbus Register Data Information

TABLE 6B

Over Current (in %)	Time To Trip (Seconds)	Over Current (in %)	Time To Trip (Seconds)	Over Current (in %)	Time To Trip (Seconds)	Over Current (in %)	Time To Trip (Seconds)
105%	470 Sec	140%	50 Sec	240%	10 Sec	410%	3 Sec
110%	225 Sec	165%	28 Sec	265%	8 Sec	430%	2.75 Sec
115%	150 Sec	185%	20 Sec	300%	6 Sec	450%	2.5 Sec
120%	110 Sec	205%	15 Sec	325%	5 Sec	475%	2.75 Sec
125%	85 Sec	220%	12.5 Sec	360%	4 Sec	500%	2.0 Sec

Time to Trip Chart

TABLE 7

Oil Temperature Sensor Installation Con't

5) When using two (2) Model 610 Digital Current Monitors for the Dual Model 610 Part (Split) Winding Motor installation, wire the oil sensor wires to *either* of the #1 and #2 Model 610 OIL+ and OIL- terminals.

NOTE: In this case, the #1 and #2 Model 610's Modbus RTU addresses will be different. Therefore, *both* the #1 and #2 Model 610's register data **must** be identical.

6) Refer to the **Sequence of Operation** section, steps 14 thru 31 for selecting the oil sensor's temperature trip value.

7. This completes the Model 610's oil sensor hardware installation.

Modbus RTU Installation

1) Referring to **Figure 7, Model 610 Exhaust Sensor, Oil Sensor and Modbus Wiring Diagram**, (page 13) connect the Model 610's "MODA", "MODC" and "MODB" terminals to the Modbus RTU connection.

NOTE: The Model 610's Modbus terminals are defined as:

MODA = TX+, MODC = Gnd, MODB = TX-

2) When using two (2) Model 610 Digital Current Monitors for the Dual Model 610 Part (Split) Winding Motor installation, wire the Modbus RTU connection to *both* sets of the #1 and #2 Model 610 "MODA", "MODC" and "MODB" terminals.

NOTE: In this case, the #1 and #2 Model 610's Modbus RTU addresses will be different. Therefore, *both* the #1 and #2 Model 610's register data **must** be identical.

3) This completes the Model 610's Modbus hardware installation.

Initial Checkout Procedure

The Model 610 Digital Current Monitor was intentionally shipped from the factory with a very low current trip value of one (1) amp. When 24 VAC power is applied, for the first time, the Model 610(s) should trip within two (2) seconds and disable the motor contactor(s) from supplying line power to the motor (load).

The one (1) amp trip level was chosen to ensure the wiring and operation of the Model 610 Digital Current Monitor and motor contactor(s) prior to setting the application specific trip current.

Before turning on power:

1) Verify (double check) all Model 610 controller(s) and motor contactor(s) motor (load) wiring.

2) Disable the motor contactor's ability to activate, by temporarily removing and protecting the 24 VAC motor contactor's coil wire connected to the N.C. terminal on the Model 610's TRIP relay or #1 Model 610's TRIP relay if using two (2) Model 610s.

3) Apply 24 VAC power to the controller and line power to the motor contactor(s). Verify the motor contactor(s) do not energize the motor. Also verify the LCD screen shows 0.0 amps.

4) Turn off both the controller's 24 VAC power and line power

to the motor contactor(s).

5) Reconnect the motor contactor(s)' 24 VAC TRIP relay wire (removed in step 2 above) to the TRIP relay's N.C. terminal.

6) Apply 24 VAC power to the Model 610 or #1 and #2 Model 610 controllers and line power to the motor contactor(s).

7) Verify the red TRIP LED comes on, within 2 seconds, and that the motor contactor(s) has / have disconnected line voltage from the motor(s).

8) Verify the motor stops and the LCD indicates TRIPPED.

9) If the motor contactor **did not** disconnect line voltage to the motor, turn off the line voltage going to the motor contactor(s) and verify the motor turns off. Then go to step 12 below.

10) The 610's LCD display should indicate the type of trip that occurred. If the trip was due to over current, then the Model 610 Control(s) and motor contactor(s) wiring has been installed correctly and both devices are working properly. Go to step 13.

11) If the controller tripped due to any other reason, such as phase imbalance, phase order, or temperature out of range, correct the problem(s) before re-applying line voltage to the motor contactor(s).

NOTE:

Phase imbalance can be caused when single phase loads are not distributed evenly throughout a 3 phase power network.

12) Refer to this I&O's **Installation** section (on pages 3 thru 9 and 12 thru 15) and the appropriate wiring diagram(s) to trouble shoot and correct the problem(s) that allowed the motor to keep running after a TRIP occurred. After each repair, the installer **must** repeat this entire **Initial Checkout Procedure** section to ensure the repair fixed the problem(s).

13) Once the Model 610 Digital Current Monitor(s) and motor contactor(s) is /are working correctly, the installer can change the current trip level to the desired value for the application, (typically motor FLA + 8% [FLA times 1.08]). See step 2 in the "**Sequence of Operation**" section (page 16) for the procedure. You may now manually reset the Over Current Trip by pressing the **MODE** button once and then the **ENTER** button once.

If a three (3) phase motor runs backwards, the installer must turn off line power to the motor and 24 VAC to the Model 610, then swap the L1 and L2 wires going to the motor and also swap the CT1+ and CT2+ wires at the Model 610's terminal block.

NOTE: Phase order verification can be turned off, using the menu system. Refer to the **Sequence of Operation**, step 7, for the details

Modbus RTU Operation

The two Model 610 Digital Current Monitors, P/N Model 610-1PH(MOD) & P/N Model 610-3PH(MOD) contain a Modbus Slave that responds to a Modbus Master, which can send requests to read the Model 610's internal register data or write new data into the 610's internal registers. The Modbus connection to the controller is an industry-standard three wire Modbus RTU

Modbus Operation Con't

(Remote Terminal Unit) RS-485 serial data link that can be shared with other modbus capable controllers and sensors.

There are 30 Modbus internal data registers (numbered 0 - 29) available in this controller, as listed in **Tables 6A & 6B, Model 610 Modbus Register Data Information**, on pages 13 & 14. Each Modbus register contains 16 data bits which can be updated using.

- Modbus command 03, to read the data from one or more, of the 610's internal data registers at a time.
- Modbus command 16 (hexadecimal 10), to write data to one or more of the internal data registers.
- Modbus command 06, to write data to a single internal data register.

To update any or all of the Model 610 Digital Current Monitor's mode, menu and submenu parameters and numerical values remotely, proceed with the following steps:

- Set MODBUS RTU slave address, baud rate and parity for each Model 610 slave installed.
- Write to each slave using the **TABLE 6A & 6B** information (pages 13 & 14) to select the Model 610's internal register numbers and associated data, as required, to set up the current monitor's operating parameters and numerical values.



IMPORTANT:

If any of the down loaded Modbus data is incorrect, the Model 610 Digital Current Monitor's microcontroller will change the incorrect data into software selected default values during the Model 610's next operating cycle. Therefore, after updating any data remotely, the operator MUST allow the Model 610 to operate for a brief time period before reviewing ALL of the data contained in each of the Model 610's 30 register addresses to 1) ensure that all of the operating parameters and numerical values, needed for the application, have been correctly selected and 2) also ensure that any unneeded or undesired options or numerical values have not inadvertently been left selected.

- Allow the Model 610 to operate for a brief period of time before reviewing all the data contained in the 30 internal registers, to ensure correct operation.

The default Modbus settings, stored within the controller, are:

- Modbus slave address = 1.
- Baud rate = 19200.
- Even parity.

Sequence of Operation

Refer to **Figure 6, the "Model 610 Menu System Flow Chart"** on pages 10 & 11, or follow the steps below to review or update all the parameters and numerical values used by the Model 610. All settings and values are stored and saved within the controller's memory.

1. With line power, to the motor contactor, turned off and with 24VAC power applied to the Model 610 controller:

- Verify no error messages are displayed on the LCD.
- Verify the LCD screen shows **0.0** amps.

2. Press the **MODE** button twice. The display should indicate "Current Trip Settings."

3. Press the **ENTER** button. The display should indicate "Number of Phases."

4. Use the **UP** and **DOWN** buttons to select the number of current transformer phases that are connected to the controller. Range is "**0 Phase; Temp only**", **Single Phase** or "**3 Phase**". Use "**0 Phase; Temp only**" when *only* temperature sensing is desired. Then press the **ENTER** button. The default is **Single Phase**.

5. The display should read: "**Set the Trip Level in Amps**". Use the **UP** and **DOWN** buttons to select a trip current appropriate for the application. Range is in 0.5 amp increments between 1.0 and 24.5 amps and in 1.0 amp increments between 25 and 200 amps. Then press the **ENTER** button. The default is 1.0 amps.

Use 1.08 1.10 and 1.15 examples here

6. If you selected the **3 Phase** option, in step 4 above, the next display will be "**Phase Imbalance Allowed**". Use the **UP** and **DOWN** buttons to choose a percent phase imbalance ranging from 2% to 100%. Press the **ENTER** button when correct. The default is 30%.

7. If you selected the **phase** option in step 4 above, the next display will be "**Check Phase Order?**" When selected, phase order is verified each time line voltage is applied to the load. Use the **UP** and **DOWN** buttons to select "**Yes**" or "**No**" and press the **ENTER** button. The default is "**Yes**".

8. The menu should have returned to the Home Screen. Now press the **MODE** button three times. The display should indicate "**Temperature Trip Settings**".

9. Press the **ENTER** button. The display should indicate "**Use Exhaust Temp?**" Use the **UP** and **DOWN** buttons to choose "**Yes**" or "**No**" and press the **ENTER** button. The default is "**No**".

10. If you selected "**Yes**" in the previous step, the next display will be "**Exh Sensor Type**". Use the **UP** and **DOWN** buttons to choose the type of sensor used. The range is "**Omega 10K**", "**PTC**" or "**NTC**". Then press the **ENTER** button. The default is "**Omega 10K**".

11. If you selected "**Omega 10K**" in step 10 above, the next screen will be "**Exhaust Temp Value**". Use the **UP** and **DOWN** buttons to select the desired high exhaust trip value in °F. The range is 80°F to 300°F. Press the **ENTER** button to save the value. The default is "**0**".

12. If you selected "**PTC**" in step 10 above, the next display will be "**Exhaust Trip Value**" in "**Ohms**". Use the **UP** and **DOWN** buttons to select the desired high exhaust trip resistance value in

Sequence of Operation Con't

ohms. The range is 100 Ohms to 20.0K Ohms. Press the **ENTER** button to save the value. The default is "0"

13. If you selected "NTC" in step 10 above, the next display will be "Exhaust Trip Value" in "Ohms". Use the **UP** and **DOWN** buttons to select the desired high exhaust trip resistance value in ohms. The range is 100 Ohms to 20.0K Ohms. Press the **ENTER** button to save the value. The default is "0"

14. If you selected "No" in step 9 above, the display will now indicate "Use Oil Temp?" Use the **UP** and **DOWN** buttons to choose "Yes" or "No" and press the **ENTER** button. The default is "No".

15. If you selected "No" in the previous step, the menu should have returned to the Home Screen. Now press the "MODE" button four (4) times. The display should indicate "Trip Auto Reset and Alarm". Go to step 34, on page 19, to continue with the next display.

16. If you selected "Yes" in step 14 above, the next display will be "Oil Sensor Type". Use the **UP** and **DOWN** buttons to choose the type of sensor used. The range is "Omega 10K", "PTC" or "NTC". Then press the **ENTER** button. The default is "Omega 10K".

17. If you selected "Omega 10K" in step 16 above, the next screen will be "Oil Temp Trips On?". Use the **UP** and **DOWN** buttons to select "High", "Low" or "Both" high and low temperature trip values in °F. Press the **ENTER** button to continue. The default is "High".

18. If you selected "High" temperature in the previous screen, the next display will be "Set Oil High Trip" in °F. Use the **UP** and **DOWN** buttons to select the desired high oil trip temperature value in °F. The range is 20°F to 200°F. Press the **ENTER** button to save the value. The default is "0"

19. If you selected "Low" temperature in step 17 above, the next display will be "Set Oil Low Trip" in °F. Use the **UP** and **DOWN** buttons to select the desired low oil trip temperature value in °F. The range is 20°F to 200°F. Press the **ENTER** button to save the value. The default is "000"

20. If you selected "Both" high and low temperature trip points in step 17 above, the next display will be "Set Oil High Trip" in °F. Use the **UP** and **DOWN** buttons to select the desired high oil trip temperature value, in °F. Then press the **ENTER** button. The default is "0".

21. The next display should be "Set Oil Low Trip" in °F. Use the **UP** and **DOWN** buttons to select the desired low oil trip temperature value in °F. The range is 20°F to 200°F. Press the **ENTER** button to save the value. The default is "000".

22. If you selected "PTC" in step 16 above, the next display will be "Oil Temp Trips On?". Use the **UP** and **DOWN** buttons to select "High", "Low" or "Both" high and low temperature trip values in ohms (resistance). Press the **ENTER** button to continue. The default is "High".

23. If you selected "High" in the previous test step, the next display will be "Set Oil High Trip" in "Ohms". Use the **UP** and **DOWN** buttons to select the desired high oil trip temperature

value in ohms (resistance). The range is 250 Ohms to 50.0K Ohms. Press the **ENTER** button to save the value. The default is "0".

24. If you selected "Low" in test step 22 above, the next display will be "Set Oil Low Trip" in "Ohms". Use the **UP** and **DOWN** buttons to select the desired low oil trip temperature value in ohms (resistance). The range is 250 Ohms to 50.0K Ohms. Press the **ENTER** button to save the value. The default is "000".

25. If you selected "Both" high and low temperature trip points in step 22 above, the next display will be "Set Oil High Trip" in "Ohms". Use the **UP** and **DOWN** buttons to select the high oil trip temperature value in ohms (resistance) and then press the **ENTER** button. The default is "0" ohms.

26. The next display should be "Set Oil Low Trip" in "Ohms". Use the **UP** and **DOWN** buttons to select the desired low oil trip temperature value in ohms. The range is 250 Ohms to 50.0K Ohms (resistance). Press the **ENTER** button to save the value. The default is "000" ohms.

27. If you selected "NTC" in step 16 above, the next display will be "Oil Temp Trips On?". Use the **UP** and **DOWN** buttons to select "High", "Low" or "Both" high and low temperature trip values in ohms (resistance). Press the **ENTER** button to continue. The default is "High".

28. If you selected "High" in the previous test step, the next display will be "Set Oil High Trip" in "Ohms". Use the **UP** and **DOWN** buttons to select the desired high oil trip temperature value in ohms (resistance). The range is 250 Ohms to 50.0K Ohms. Press the **ENTER** button to save the value. The default is "0" ohms.

29. If you selected "Low" in test step 27 above, the next display will be "Set Oil Low Trip" in Ohms. Use the **UP** and **DOWN** buttons to select the desired low oil temperature trip value in ohms. The range is 250 Ohms to 50.0K Ohms (resistance). Press the **ENTER** button to save the value. The default is "000".

30. If you selected "Both" high and low temperature trip points in step 27 above, the next display will be "Set Oil High Trip" in "Ohms". Use the **UP** and **DOWN** buttons to set the high oil trip temperature value in ohms and then press the **ENTER** button. The default is "0" ohms.

31. The next display should be "Set Oil Low Trip" in "Ohms". Use the **UP** and **DOWN** buttons to select the desired low oil trip temperature value in ohms (resistance). The range is 250 Ohms to 50.0K Ohms. Press the **ENTER** button to save the value. The default is "000" ohms.

32. The menu should have returned to the Home Screen. Press the **MODE** button four (4) times.

33. The display should indicate: "Trip Auto Reset and Alarm".

34 Press the **ENTER** button. The display should indicate "# Trips Until Manual Reset:" Use the **UP** and **DOWN** buttons to select a number (range is 0 to 255) then press the **ENTER** button. The default is "3".

35. The display will indicate "Auto Reset Delay Time". Use the **UP** and **DOWN** buttons to select between 0 to 255 minutes and press the **ENTER** button. The default is "5" minutes.

36. The display should indicate "Extern Alarm When". Use the **UP** and **DOWN** buttons to select one of the following options:

Sequence of Operation (con't)

“No Manual Reset” – The external alarm is activated if there has been at least one trip without a manual reset being performed.

“Man Reset Required” – The external alarm is only activated if the control is in lockout and a manual reset is required.

“Tripped” – The external alarm is activated whenever the control is tripped. Press the ENTER button after making your selection.

37. The menu should have returned to the Home Screen. Press the MODE button five (5) times. The display should indicate “Modbus Settings”. If you are not using the Modbus for remote control, press the MODE button, once more, and go to step 41.

38. Press the ENTER button. The display should indicate “Set Modbus Address”. Use the UP and DOWN buttons to select a Modbus slave address for this controller. The range is 1- 247, then press the ENTER button. The default is “1”.

39. The display should indicate “Modbus Baud Rate”. Use the UP and DOWN buttons to select the correct value used by the Modbus RTU master computer. The default is 19200 baud. See TABLE 8 (below) for the other selectable baud rates. Press the ENTER button after making your selection.

Code	Baud Rate	Code	Baud Rate
0	1200	4	19200
1	2400	5	38400
2	4800	6	57600
3	9600	7	115200

Baud Rate Codes

TABLE 8

40. The display should indicate “Modbus Parity.” Use the UP and DOWN buttons to select the correct parity used by the Modbus RTU master computer. The choices are “even parity, odd parity or no parity”. Press the ENTER button. The default is even parity.

41. The display should indicate “Reset Control to Factory Sets?” The default is “No.” Press the ENTER button.

IMPORTANT: If you select “Yes” and press the ENTER button, all the Model 610 Digital Current Monitor’s parameters are reset to the following factory default settings:

- Single Phase monitoring.
- Trip Level = 1.0 amp.
- Exhaust and Oil temperature sensors are not used.
- Lockout occurs when the 3rd trip occurs.
- Auto reset delay = 5 minutes.
- Modbus slave address = 1.
- Modbus baud rate = 19200.
- Modbus parity = even.

This completes the setup of all control parameters.

Final Checkout Procedure

Reconnect any previously removed wires, apply 24 VAC power to the Model 610 Digital Current Monitor and line power to the motor contactor. Observe the LCD screen and the motor’s operation:

- Verify the current displayed on the Model 610’s LCD screen matches the motor’s FLA current.
- If the exhaust and / or oil temperature sensors are used in this application, verify the temperatures displayed on the LCD screen match the measured exhaust / oil temperatures recorded by the installer (using an appropriate temperature sensing device).
- If the system works correctly, no operational updates are needed.
- If the system does not work correctly, determine the specific cause for the anomaly and fix it. When the anomaly’s solution involves an update to the Model 610 Digital Current Monitor’s parameters, follow the **Sequence of Operation** instructions (pages 16 thru 18) to update the specific parameter(s) needed to achieve the best possible system operation. After any update(s) or repairs have been made, observe the entire system’s operation again, to verify the update(s) or repairs worked.

Motor & Operating Tips

Motor Tip

For motors drawing less than 5 amps, each motor’s power wire can be looped through its associated CT a number of times (depending on wire diameter) to increase the sensed current.

Important: Adjust the current trip value accordingly.

For example:

A single phase motor with an FLA of 2.0 amps, can be protected with a Model 610 Digital Current Monitor, by looping one of the motor’s power wires through the CT three (3) times. In this case, the Model 610 will sense the motor’s FLA as 6 amps (3 wire loops times the 2 amp FLA current).

The current trip value is determined by selecting the allowed overcurrent percentage and using the following formulas:

$$\text{Overcurrent Ratio} = (\text{overcurrent percentage} + 100\%) \text{ divided by } 100.$$

$$\text{Trip Value} = \text{Overcurrent Ratio times FLA times } 3 \text{ (wire loops)}$$

For an 8% over current, the Trip value is:

$$\text{Overcurrent Ratio} = (8\% + 100\%) / 100 = 1.08$$

$$\text{Trip Value} = 1.08 \text{ times } 2 \text{ amps times } 3 \text{ wire loops} = 6.48 \text{ amps.}$$

Use a trip value of 6.5 amps.

Operating Tip

The speed at which the LCD screen’s values change is variable. Holding the UP or DOWN button down causes the displayed value to change slowly at first and then speed up noticeably. When making large value changes hold the button down until the displayed number is close to the desired value. Then release the button, wait 1 second, and press the button down again to slowly reach the desired value.

This page is intentionally left blank

Troubleshooting Guide

Condition	Cause	Solution
Motor Does Not Run	<ol style="list-style-type: none"> 1. Motor not wired correctly. 2. Phase rotation incorrect. 3. Control locked out. 4. Motor off on internal overload. 	<ol style="list-style-type: none"> 1. Check and correct wiring. 2. Correct power wiring. 3. Determine lockout cause and reset control. 4. Determine why overload occurred and correct problem.
Current Trip Not Occurring	<ol style="list-style-type: none"> 1. Trip relay N.O. and COM terminals not wired correctly. 2. Displayed current not staying above the current trip value long enough for the excess motor energy to rise to the equivalent of a locked rotor for 2 seconds. 3. Current transformers not oriented correctly. 4. Current transformers not wired correctly. 	<ol style="list-style-type: none"> 1. Check wiring, review instructions. 2. Use Time to Trip, Table 7 to look up the trip time and verify motor turns off appropriately. If not replace control. 3. Orient all transformers identically. 4. Check and correct wiring.
Home Screen Shows Incorrect or Zero Amps Value	<ol style="list-style-type: none"> 1. Current transformer(s) not connected or bad. 2. Current transformers not oriented correctly.. 3. Current transformer(s) incorrectly wired. 4. Control is bad. 	<ol style="list-style-type: none"> 1. Check wiring / replace transformer(s). 2. Orient all transformers identically. 3. Check and correct wiring 4. Replace control.
Temperature Trip Fails to Occur	<ol style="list-style-type: none"> 1. Temperature sensor is not an R - T type thermistor sensor. 2. Incorrect temperature sensor option selected (10K, PTC or NTC). 3. Incorrect temperature selected (Modbus = Temp °F times 10). 	<ol style="list-style-type: none"> 1. Use correct temperature sensor. 2. Select correct temperature sensor option. 3. Use correct temperature value.
LCD Screen is Blank	<ol style="list-style-type: none"> 1. Power not turned on. 2. Bad 24 VAC transformer. 3. Microcontroller is hung up (paused). 4. Control is bad. 	<ol style="list-style-type: none"> 1. Turn on 24 VAC. 2. Replace 24 VAC transformer. 3. Cycle 24 VAC power and recheck. 4. Replace control.

Hoffman|Controls