

Hoffman|Controls Installation & Operating Instructions

CAUTION



Failure to read and understand the accompanying instructions and diagrams or failure to complete the “Checkout Procedure” prior to energizing the Control may result in permanent damage to the Control.

General

The 865D-2 Low Ambient Three (3) Phase Head Pressure Control is designed to modulate three phase condenser fan Motors in air conditioning and refrigeration systems. The control monitors the head pressure by sensing 1) the sub-cooled liquid line temperature, or 2) via a 0-10 VDC or 4-20 mA control signal indicating the system's pressure. The controller varies the air volume through the condenser thus regulating head pressure for proper heat rejection in low ambient conditions.

The 865D-2 Series installation instructions are limited to three phase, direct connected, propeller type, condenser fan motor applications. These applications require continuously variable speed High Slip tolerant/Ventilated (HS/V), 850/1150 RPM, direct drive, vertical shaft designed motors approved by the motor manufacturer for continuous variable speed operation.

The installation, start-up and servicing of the 865D-2 Control and the continuously variable speed motor can be hazardous due to the technical scope and magnitude of the electrical/mechanical components encountered.

A qualified technician with knowledge and experience in controls and refrigeration will be required. All safety precautions, instructions, labels, and tags on the items being installed as well as those of the equipment manufacturer should be observed.

The 865D-2 is offered with a NEMA 3R rainproof enclosure for field installation in the weather/ambient.

Applications

The 865D-2 Control typically modulates continuously variable speed HS/V (High Slip/Ventillated) three (3) phase condenser fan motor(s). Two identical condenser motors, of same manufacturer, type, model, RPM and identical propeller fans, may be controlled by one 865D-2 Control. In either case, the 8 amp, per phase, rating of the 865D-2 Control must not be exceeded.

A properly applied 865D-2 Control may be used to extend the operating range of A/C or refrigeration systems, permitting operation at lower outdoor ambient temperatures. When more than two liquid line sensors require monitoring, use the Hoffman Controls 851-4MS or 851-6MS series Multiple Sensor Selector.

The 865D-2 Control can also be used as a Manual three (3)

865D-2 Three Phase Head Pressure Control

Applications Con't

phase Fan Speed Control by using the MIN SPD potentiometer or by a 0-10Vdc or 4-20mA signal

The 865D-2 can be field calibrated to optimize the throttling range of the continuously variable speed HS/V motor(s) for air-cooled condenser applications.

Controller/Motor Operation

Recalibration of the 865D-2's factory calibrated settings can be accomplished in the field when required. If recalibration is required, see settings.

The Controller is set for 50°F to 80°F operation from the factory and is designed to maintain synchronous (full) speed for all liquid line temperatures above 80°F. Below 80°F liquid temperature, (60°F ≈ ambients) the Controller initiates phase proportioning by reducing motor speed from full speed. Speed reduction continues as liquid temperature decreases down to a minimum speed which occurs at 53°F (25°F ≈ ambient).

Further reduction in liquid line sub-cooling will cycle the motor “OFF” at 50°F. The motor will restart at 53°F, 3°F differential at above where the motor cycled OFF, and modulates back to the Minimum speed. OFF time will increase as Ambients continue to fall and liquid line temperature remains below 50°F. This feature also allows the 865D-2 to be “OFF” at start-up when the ambient and liquid line are below 50°F. Conversely, the 865D-2 controls the motor speed functions in reverse as previously described as temperatures increase.

A 0–10VDC or 4–20mA optional input signal is available. These inputs may be used when pressure transducers or other analog inputs are preferred.

Operational Overview

The 865D-2 Control is factory calibrated for use with the supplied liquid line temperature sensor and is set for 50°F to 80°F operation with a typical minimum speed of 300RPM. These setting can be changed as required.

A 0–10 VDC or 4–20mA optional input signal is available. These inputs may be used when pressure transducers or other analog outputs are preferred. Also a second Temperature Sensor input is available.

A) Use the **MODE SWITCH** to select either (HP) Head Pressure Control operation or (SP) Motor Speed control operation.

B) Use the **SENSOR SWITCH** to select either a (MA) input or (S2) a second sensor input. *****Note when using (SP) MODE, SENSOR SWITCH must be in MA position.**

Operational Overview Con't

C) The 865D-2 Control will then automatically sense the type of input signal being used.

D) Use the **HIGH SET** potentiometer to select the desired maximum input signal value to operate the motor at maximum rpm. The **HIGH SET** potentiometer has three (3) scales associated with it:

- °F scale (Temperature) - Outside scale
- mA scale - Middle scale
- VDC scale - Inside scale

E) Use the **LOW SET** potentiometer to select the desired minimum input signal value to operate the motor at minimum rpm just before motor cutoff.

- The **LOW SET** potentiometer has the same three (3) scales as the **HIGH SET** potentiometer described above.

Refer to the **Modes of Operation** section (page 3) for the **MODE SWITCH**, **SENSOR SWITCH**, **HIGH SET**, **LOW SET** and **MIN SPD** potentiometers' operating details

Pre-Installation

Before field installation of the 865D-2, or the HS/V motor, the installer should carefully evaluate the physical requirements for installing the new motor and Controller. The check list below will cover the basic requirements of a field installation.

1. For use with three phase HS/V condenser fan motors capable of continuously modulating its rpm between minimum and full speed and vice versa.
2. The control provides 8 amps, per phase, of current and will typically operate up to a 2 HP motor. However, the current draw of the motor(s) selected can not exceed 8 running amps of motor drive capability.
3. The control can monitor one or two refrigerant circuits with a 10K liquid line temperature sensor or a 0 - 10 Vdc or a 4 - 20 mA input signal. The 865D-2 is supplied with one (1) temperature sensor. A second sensor can be purchased from Hoffman Controls, P/N 100-0017-001. When pressure transducers are used the installer **must provide** the transducer's power source. Both 0 - 10 VDC and 4 - 20 mA pressure transducers are market available. Additionally, in motor speed mode, the 865D-2 will accept a 0-10 VDC or a 4 - 20 mA manual or automated control signal for non-head pressure applications.
4. The control requires an external 24VAC, 4VA power source.
5. Wiring must comply with Local and National Electrical Codes.
6. Refer to 865D-2 Product Data (HCC #172-0270-000) to insure a complete understanding of the controller's functions before continuing installation.

LOW & HIGH SET Potentiometers

The **LOW SET** point and **HIGH SET** point adjustments are critical settings for proper heat rejection in low ambient condi-

tions. The 865D-2 control maintains the pressure differential at the expansion valve for proper superheat. The **LOW SET** and **HIGH SET** point potentiometers have three scales that provide settings for temperature (40°-140° F), mA (4 -20) and VDC (0 - 10). Use the scale and input signal that is appropriate for the application. Refer to **Figure 2, "865D-2 Field Wiring Diagram"** (on page 5).

Operation with Hysteresis

When the sensed input signal drops below the selected **LOW SET** point, the motor will turn off. When the input signal rises above the **LOW SET** point by the hysteresis value, the motor will turn back on. The hysteresis value for temperature is 3°F, for pressure its 6 PSI and for voltage its 0.8 Vdc.

CAUTION: These various set point adjustments are provided only to ensure proper ambient control when the system is properly charged (no vapor in the sight glass), and filters, condenser coil and evaporator coil are all clean.

LED Set point Indicator

When either the **LOW SET** or **HIGH SET** potentiometer is turned and the pot adjustment has stopped, the green **SET LED** will flash the new set point value. A sequence of flashes indicates a digit from 1-9. The number zero (0) is indicated by a longer low-brightness pulse. For example, if the set point is 105°F, the **SET LED** will flash once, then pause, then display a dim glow, then pause, then flash five times. **NOTE:** The **MODE SWITCH** must be in the **HP** position, three phase power must be applied and the **FAULT LED** must be off for the **SET LED** indicator to work. Also, the input type (Temp, Vdc or mA) is automatically detected and the **SET LED** will flash the correct values for the input type. The **SET LED** indicator provides the assurance that the set points have been entered exactly as desired.

Set Point Scale Ranges

The 865D-2 will automatically detect whether a temperature, mA or Vdc input is being used. However, note that the SENSOR Switch is used to select a second Sensor or mA type input. The set point scale ranges for these three (3) inputs are as follows:

TEMPERATURE:

The **LOW SET** potentiometer's range is from 40 °F to 80 °F, in 1 °F increments.

The **HIGH SET** potentiometer's range is from 60 °F to 140 °F, in 1 °F increments.

mA:

The **LOW SET** potentiometer's range is 4 mA to 16 mA, in 1 mA increments.

The **HIGH SET** potentiometer's range is 8 mA to 20 mA, in 1 mA increments.

VOLTAGE:

The **LOW SET** potentiometer's range is 0.5 VDC to 8.0 VDC in 0.1 volt increments.

The **HIGH SET** potentiometer's range is 6.0 VDC to 10.0 VDC, in 0.1 volt increments.

This wide range of adjustment provides head pressure control and motor rpm settings for both typical and unique applications.

Set Point Scale Ranges Con't

The **factory setting** is for the typical temperature sensed A/C application with the **MODE SWITCH** in the **HP** position, a **LOW SET** point of 50°F and a **HIGH SET** point of 80°F. This provides a 30 °F span (range) for three phase condenser fan motor modulation for the typical Thermal Expansion Valve (TXV) type systems.

The motor(s) cycles "OFF" at liquid line temperatures below 50 °F and cycles back "ON" at 53 °F liquid line temperature providing 3 °F of hysteresis between motor "OFF" and "ON" operation.

A 25 °F span (settings of 75 °F to 100 °F) is recommended for High Efficiency systems. Settings of 70 °F to 100 °F are recommended for Capillary Tube or Orifice type systems.

MIN SPD Potentiometer

The minimum speed "MIN SPD" potentiometer is factory set at 300RPM for a typical three (3) phase motor minimum speed. Adjustments to this RPM setting can be made by turning the MIN SPD potentiometer to the desired motor RPM.

With the **MODE SWITCH** in the **SPD** position and note that the **SENSOR SWITCH** must be in the **MA** position, the **MIN SPD** potentiometer can also be used as a Manual Fan Speed rpm adjustment and will control the speed of the motor from OFF to FULL speed.

Modes of Operation/Input Signals

The 865D-2 is capable of operating in two (2) different modes, Head Pressure Control or as a Motor Fan Speed Control.

When in head pressure mode (**MODE SWITCH** in the **HP** position), the 865D-2 accepts one of three inputs, one or two 10K temperature sensors (**SENSOR SWITCH** in **S2** position for two sensors), a 0-10 VDC input signal or a 4-20 mA input signal (**SENSOR SWITCH** in **MA** position for 4-20mA).

When in motor fan speed mode (MODE SWITCH in the SP position and SENSOR SWITCH must be in the MA position), the 865D-2 accepts a 0-10 VDC input, a 4-20 mA input or the **MIN SPD** pot input can be used.

To enter either mode of operation and use one of the accepted input signals, follow the instructions below;

For Head Pressure Operation:

Place the **MODE SWITCH** in the **HP** position and connect the input signal as follows:

When using the 10K sensor as the input signal;

• Connect the 10K sensor wires to terminals **S1** and **COM**.

When using two 10K sensors as the input signal;

Place the **SENSOR SWITCH** in the **S2** position

• Connect the second 10K sensor wires to terminals **S2** and **COM**. HCC P/N 100-0017-001, Dual Sensor Kit comes with a terminal fork that makes connecting two sensors to the **COM** terminal easier.

When using 0 - 10 VDC as the input signal;

- **DO NOT** use the 10K sensor. Make no connection between terminals **S1**, **COM** and **S2**.
- Connect the 0-10 VDC input signal to the **GND** and **VDC** terminals.

When using 4 - 20 mA as the input signal,

Place the **SENSOR SWITCH** in the **MA** position

- **DO NOT** use the 10K sensor. Make no connection between terminals **S1**, **COM** and **S2**.
- Connect the 4-20mA input signal to the **GND** and **mA** terminals.

For Motor Fan Speed Operation:

Place the **MODE SWITCH** in the **SP** position, **SENSOR SWITCH** in the **MA** position and connect the input signal as follows:

When using 0 - 10 VDC as the input signal;

- Connect the 0-10VDC signal to the **GND** and **VDC** terminals.

When using 4 - 20 mA as the input signal;

- Connect the 4-20 mA signal to the **GND** and **mA** terminals.

When using the MIN SPD pot for speed control;

- Manually turn the **MIN SPD** potentiometer until the desired motor rpm is obtained. The **MIN SPD** potentiometer can be adjusted from motor OFF to FULL speed.

Installation Steps

The 865D-2 Control must be installed vertically with panel conduit/wiring openings at the bottom. A 1/2" and 3/4" conduit fitting opening and a bushing for sensor or input cable is provided. However, conduit connectors are not included. The factory furnished sensor/hardware kit includes:

- One (1) 60" cable assembly and sensor.
- One (1) Special sensor installation tape.



IMPORTANT:

Do not install the 865D-2 in an airtight compartment, on a vibrating surface or near/on heat generating sources.

Installation Steps Con't



WARNING:

Disconnect power from the unit and electrically disable the compressor prior to installation to ensure both are electrically disabled prior to installation.

- Step 1** Disconnect all power, line and control voltages from equipment.
- Step 2** Disconnect control circuit to all compressor relay/contactors, disabling compressor(s).
- Step 3** **Install only continuously variable High Slip / Ventilated direct drive motors capable of continuously variable speed operation.**
- Step 4** Install Line and Low voltage wiring along with Sensor wiring, as shown in **Figure 2, Field Wiring Diagram** (on page 5) and the instructions below.
- A.** Remove wiring from condenser motor(s) at contactor(s) or terminal block and reconnect the contactor's wires to the 865D-2 terminals LOAD (A), (B) and (C).
- B.** Field furnish three (3) 90°C wires, of appropriate size for the application, from condenser fan motor contactor to the 865D-2 terminals LINE (A), (B) and (C).
Install the 865D-2 control in ventilated enclosure (indoors) or NEMA-3R enclosure (outdoors). The control is conformally coated but must be protected from moisture and condensation.
- C.** Connect green GND wire on 865D to a reliable ground.
- D.** Field furnish 24VAC transformer wiring to the 865D-2's 24V and COM terminals.
- E.** Install the supplied 10K Sensor to the top of liquid line where the line exits the condenser coil as shown below in **Figure 1, Sensor Installation Cross Section Diagram**.
- F.** Use the special tape provided in hardware kit to secure the sensor to the clean liquid line. Stretch the tape slightly, as you wrap the tape around the Sensor and liquid line. Use all the tape, lapping the Sensor. Firm contact is required between the metal tab of the Sensor and the liquid line. **Do not use tie wraps or band clamps to secure sensor to liquid line. Sensor may be damaged by doing so.**

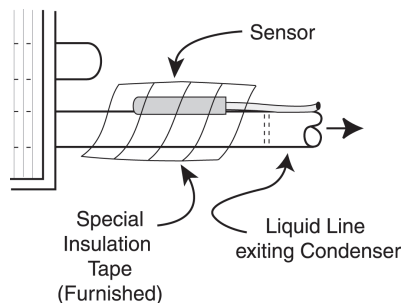

Figure 1 - Sensor Installation Cross Section Diagram

- G.** Route sensor cable from sensor location to 865D-2 Control. Up to 75 feet of additional 22 AWG, twisted pair, shielded, jacketed wire may be used to lengthen the sensor cable. Connect the sensor's wires to the control's S1 & COM input terminals. **Note:** It doesn't matter which sensor wire is connected to the S1 terminal or the COM terminal. If using two sensors, connect the second sensor to S2 terminal and the COM terminal.

- Additional insulation of the taped sensor and adjacent liquid line, back to condenser header, is typically required in cold ambients (+20°F).

- Refrigeration applications or extremely low ambient environments may require additional consideration. See Engineering Bulletin (HCC #81XEBO2REVA) for "Low Ambient Considerations".

- When monitoring three to six refrigerant circuits, install the Hoffman Controls 851-MS Series Multiple Sensor Selector as shown on page 7.

- H.** Verify unit manufacturer has provided fuse or circuit breaker protection for motors being controlled and field wiring did not remove or bypass motor protection.

- Step 5** Install DVM across LOAD (A) and (B), amp meter clamp on (C) wire and temperature indicator on liquid line.

- Step 6** Temporarily remove one of the temperature sensor(s) leads from S1 and S2 if using two sensors. If using a VDC or mA input, remove that input. With all inputs removed, this will cause the 865D-2 Control to run the condenser motor(s) at full speed.

- Step 7** Phase Sequence Verification

- A.** Apply line and control voltage to unit(s) observing voltage and current to motor being controlled.
- B.** All fan motor(s) should start. Compressor should not start as a result of previous disabling instructions.
- C.** If 865D-2 controlled fan motor(s) start, phases are in sequence. Proceed to Step 8.
- D.** If motor(s) does not start:
LINE (A), (B) and (C) line voltage input to Controller has incorrect phase sequencing:
- FAULT LED will be on.
 - Remove power.
 - Reverse line wires attached to LINE (A) and (B) terminals on 865D-2 and restore power to unit.
 - Motor(s) will start.
 - FAULT LED will be off. MTR SPD LED will be full on (not blinking).

- Step 8** Condenser Fan Rotation Verification

- A.** Check condenser for proper airflow (CW or CCW motor rotation).
- B.** If motor rotation is correct; proceed to Step 9.
- C.** If motor rotation is incorrect, remove power and reverse wires on 865D terminals LOAD (A)&(B).
- D.** Re-connect control circuit that disabled com-

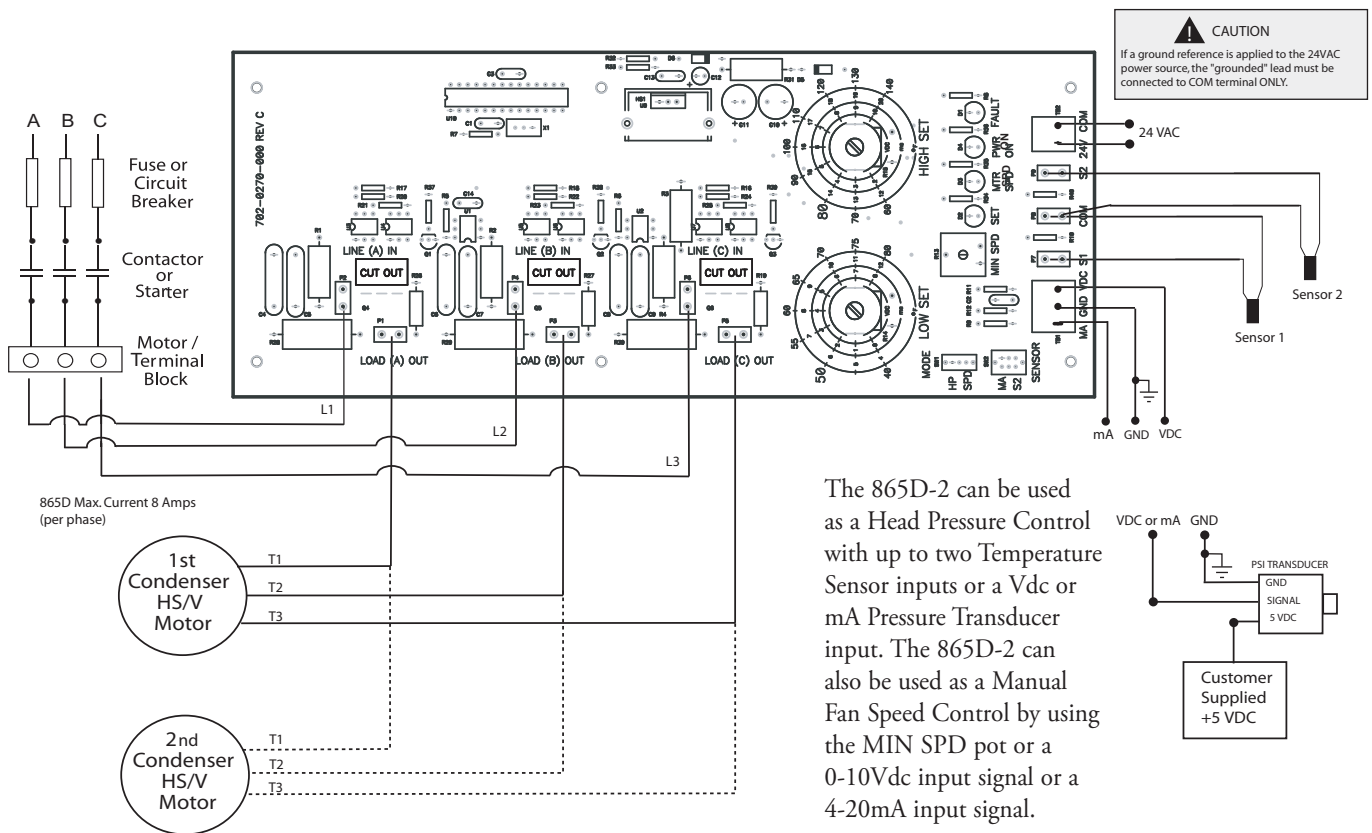

Figure 2 - Field Wiring Diagram

Installation Instructions Con't

pressor(s) in Step 2.

- E. Restore power to unit. Compressor and condenser fans will start. Recheck condenser fan(s) for proper airflow.

NOTE:

The completion of Steps 1 through 8 verifies the integrity of the electrical installation. The following evaluation in Step 9 will validate the performance of the 865D-2 Control and HS/V motor.

Step 9 Monitor operation of the 865D-2 and motor(s) at full speed.

- A. Observe the motor's AC voltage and current. Also monitor liquid line temperature, then verify the MTR SPD LED is full on.
- B. When above measurements are correct, reconnect the input signal.
- C. Depending upon the observed liquid line temperature, the following performance values should be observed.
 - 1) As liquid line temperatures decrease from selected HIGH SET temperature to selected LOW SET

temperature:

- Motor speed (RPM) decreases.
 - Voltage to motor decreases (when viewed on RMS meter).
 - Current increases, peaks, then decreases.
- 2) As liquid line temperatures increase from selected LOW SET temperature to selected HIGH SET temperature:
- Motor speed (RPM) increases.
 - Voltage to motor increases (when viewed on RMS meter).
 - Current (amps) increases, peaks, then decreases.

Liquid Temperature	Motor Speed (RPM)	MTR SPD LED status
Above HIGH SET point	1150≈	Full On
Between HIGH & LOW SET points	<1150 to 300	Blinking
Below LOW SET point	Zero	Full Off

Checkout Procedure



CAUTION

Verify all three phase motor connections & 865D-2 connections are correct before applying power.

1. Verify line voltage is correctly applied to the motor(s) terminals.
2. Verify motor(s) has been programmed for correct rotation (CW/CCW) and is selected for the recommended propeller

Prepare for Operation

1. It is recommended that the compressor be disabled prior to control and condenser fan motor(s) operational checkout.
1. Apply power to both the 865D-2 and condenser fan motor(s). Verify the FAULT LED is off.
2. Once the control and motor(s) wiring has been verified, restore the compressor's power.
3. Set thermostat for cooling demand and apply voltage to the unit. Condenser fan(s) will start if the liquid line is 3°F above the selected **LOW SET** point temperature value and modulate over the span of the range selected.
4. Verify that the motor is operating properly for liquid line temperatures sensed. Depending on the **LOW & HIGH SET** points, when the sensor's temperature at start up is:
 - a. **Below Selected Range**, the motor(s) will not start.
 - b. **Within Selected Range**, the motor(s) will start and the 865D-2 will modulate the motor's rpm proportionally to the temperature sensed.
 - c. **Above Selected Range**, the motor(s) will start and then remain at full speed.
5. Verify operation as described above by monitoring liquid line temperature and observing motor speed.
6. When using pressure transducers (VDC or mA) or BAS inputs, monitor the control signal versus motor rpm for proper operation.

New Motor Installation Checklist

1. Verify the existing motor's bracket/support accepts the NEW HS/V continuously variable, 56 frame (6 1/2") diameter motor.
2. Verify the existing fan blade accepts the NEW HS/V motor's 5/8" diameter shaft.

Controller Installation Check List

Where will the 865D-2 be located:

1. Inside a ventilated control panel?
2. Mounted externally in ambient (exposed to the weather) on the unit adjacent to the existing motor/control panel?
3. To allow access to wiring connections and calibration adjustments?



CAUTION

865D Series Head Pressure Controllers are not suitable for mounting inside a totally enclosed or non ventilated control panel that exceeds 160°F (70°C).

NOTE:

When using the 865D-2 as a Fan Speed Control, the **MODE SWITCH** must be in the **SPD** position and the **SENSOR SWITCH** must be in the **MA** position for proper operation.

NOTE:

When using the 865D-2 as a Head Pressure Control, removing all input signals, Sensor(s) or Vdc/mA input signals will allow the motor(s) to start and operate at full speed without concern for the input and will verify the control and motor(s) are operating correctly.

NOTE:

The 865D-2 Control is factory calibrated for use with the supplied liquid line temperature sensor and is set for 50°F to 80°F operation with a minimum speed of 300RPM. These settings can be changed as required.

HOFFMAN I CONTROLS 865D-2/851-MS Combination Wiring Diagram for Head Pressure Installations Requiring More Than Two Sensor Inputs

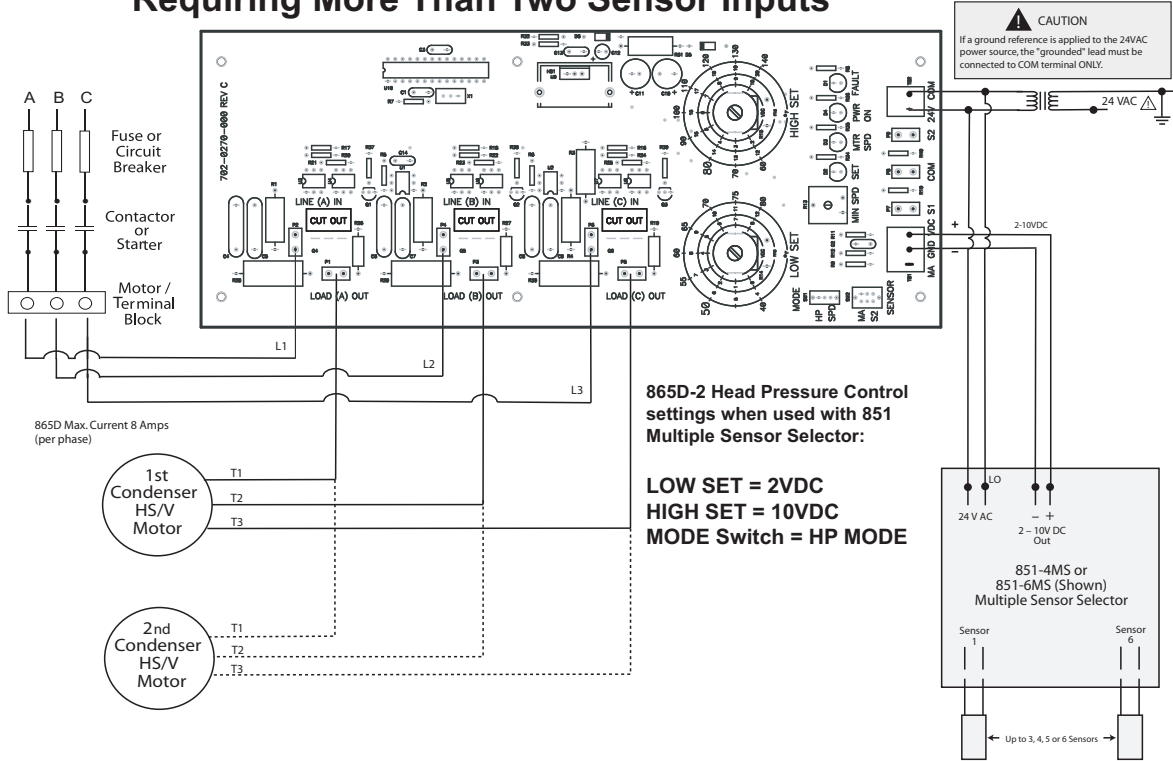

Low Ambient, Condensing, Sub Cooling, and Liquid Line Values for Constant, Variable, and Fan Cycling Operations

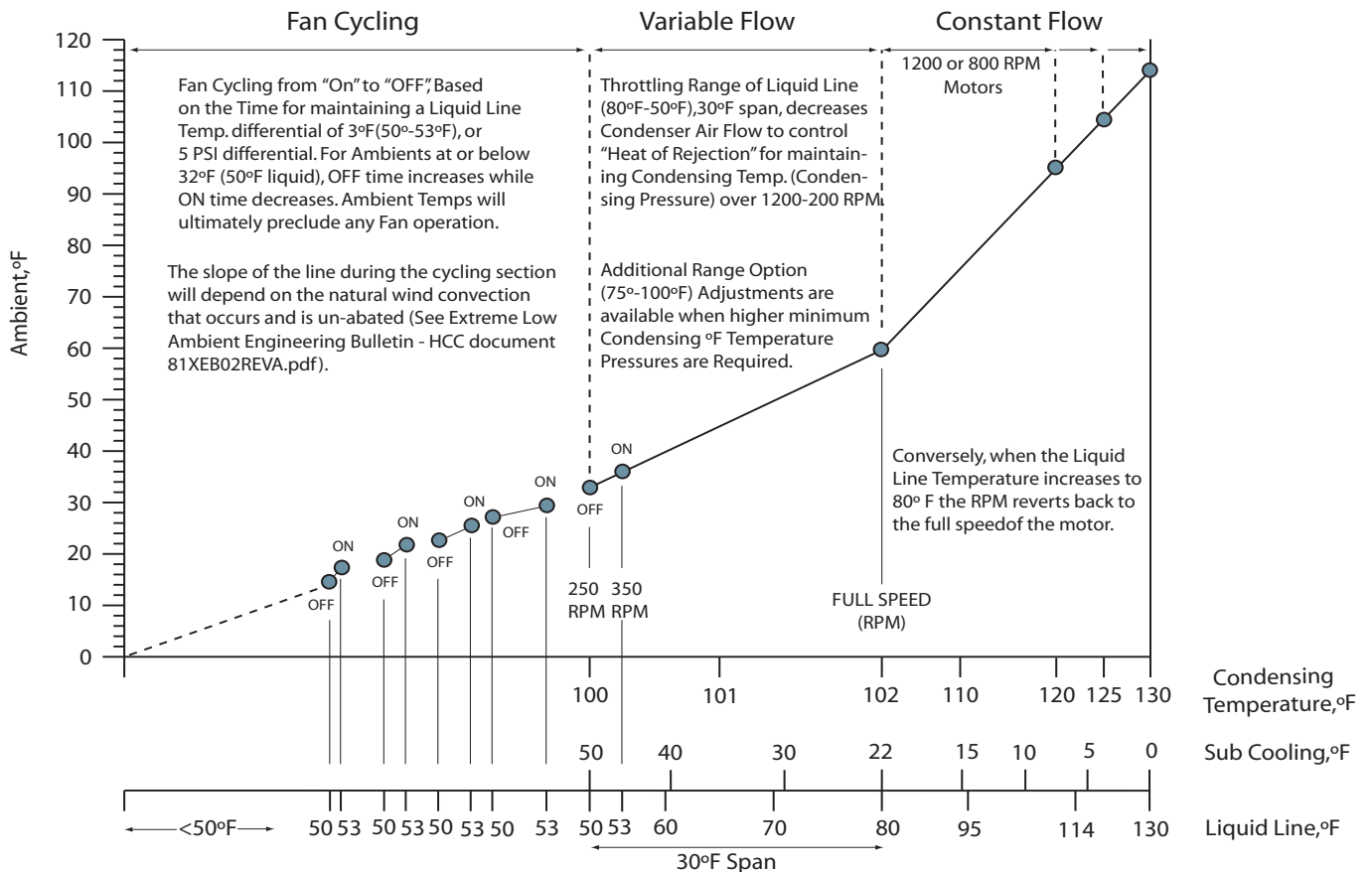

Typical Fan Operation with Ambient, Condensing, and Liquid Line Temperatures

Temp °F	Sensor (Ohms)	Temp °F	Sensor (Ohms)	Temp °F	Sensor (Ohms)
40.0	26,109	64.0	13,823	88.0	7,685
42.0	24,712	66.0	13,139	90.0	7,332
44.0	23,398	68.0	12,492	92.0	6,997
46.0	22,160	70.0	11,881	94.0	6,679
48.0	20,996	72.0	11,3033	96.0	6,378
50.0	19,899	74.0	10,8509	98.0	6,092
52.0	18,872	76.0	10,2095	100.0	5,820
54.0	17,903	78.0	9,750	102.0	5,561
56.0	16,990	80.0	9,287	104.0	5,316
58.0	16,128	82.0	8,848	106.0	5,094
60.0	15,315	84.0	8,433	108.0	4,873
62.0	14,547	86.0	8,056	110.0	4,662

Temperature to Resistance Table - Key Point Values
Table 1

Troubleshooting Guide		
Condition	Cause	Solution
Motor Will Not Run	<ol style="list-style-type: none"> 1. Improper installation, Motor not wired correctly. 2. Sensor temp below LOW SET point value. 3. Motor "OFF" on internal overload. 	<ol style="list-style-type: none"> 1. Check wiring, review instructions. 2. Normal operation. 3. Motor protected.
Motor Runs at Full Speed Only	<ol style="list-style-type: none"> 1. Motor not wired correctly. 2. Motor not wired correctly. Control damaged. 3. Low refrigerant. (Hot gas in liquid line.) 4. Sensor opened. (Verify Ohms vs. Temp.) 5. Sensor temp above HIGH SET point value. 	<ol style="list-style-type: none"> 1. Check wiring, review instructions. 2. Replace control. 3. Charge system. 4. Replace Sensor. 5. Normal operation.
Motor Overheats	<ol style="list-style-type: none"> 1. Minimum speed set too low. 2. Motor design not applicable for continuously variable speed operation. 	<ol style="list-style-type: none"> 1. Raise MIN SPD RPM. 2. Replace motor.
Motor Will Not Modulate Properly	<ol style="list-style-type: none"> 1. Sensor not properly located or attached to liquid line. 2. Fan blade does not load motor at full RPM (speed). 3. Sensor resistance (in ohms) vs. temperature (in °F) not in compliance with values in Table 1. 4. Motor design not applicable for continuously variable speed operation. 5. System not properly charged. 6. Expansion valve is not properly metering refrigerant; cap tube or orifice not properly sized for low ambient operation. 7. Low evaporation and head pressure. 	<ol style="list-style-type: none"> 1. Relocate per instructions. 2. Compare FLA rating to measured FLA. 3. Replace Sensor. 4. Replace Motor. 5. Recharge system. Add or remove refrigerant. (Liquid line must not indicate vapor/gas.) 6. Adjust or replace expansion valve, cap tube or orifice to provide proper control of lowside. 7. Reset LOW & HIGH pots CW to provide evaporator temperature above 32°F.

Hoffman|Controls